

Installation Manual

SENECA PRIVACY ARBOR - SPA8

YM14126



**YARDISTRY**[®]

Yardistry - North America
Toll Free Customer Support: 1.888.509.4382
info@yardistrystructures.com
www.yardistrystructures.com

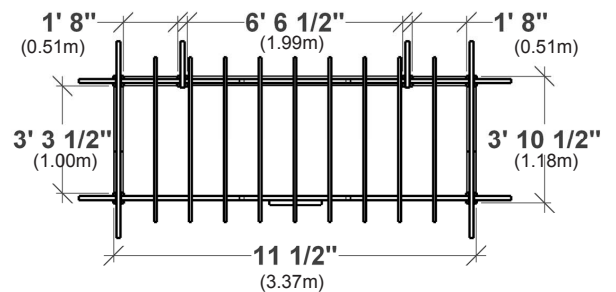

Revised April 12, 2018

Important Safety Notice!

Yardistry components are intended for privacy, decorative and ornamental use only.

Product is NOT INTENDED for the following:

- A safety barrier to prevent unsupervised access to pools, hot tubs, spas or ponds.
- As load bearing support for a building, structure, heavy objects or swings.
- Used in structures that trap wind, rain or snow that would create extra load on the product.

Accumulated snow must be removed from roof.

DO NOT climb or walk on roof for any reason.

Permanent structures may require a building permit. As the purchaser and or installer of this product you are advised to consult local planning, zoning and building inspection departments for guidance on applicable building codes and/or zoning requirements.

Wood is NOT flame retardant and will burn. Grills, fire pits and chimineas are a fire hazard if placed too close to a Yardistry structure. Consult user's manual of the grill, fire pit or chimenea for safe distances from combustible materials.

Wear gloves to avoid injury from possible sharp edges of individual elements before assembly.

During installation, follow all safety warnings provided with your tools and use OSHA approved safety glasses. Some structures may require two or more people to install safely.

Check for underground utilities before digging or driving stakes into the ground!

It is important during assembly to closely follow the instructions, complete the assembly on a solid level surface and that you follow the instruction to square up, level and anchor the structure, this will reduce the gap at wood connections during assembly.

General Information

General Information: Wood components are manufactured with Cedar (C. Lanceolata) which is protected with factory applied water-based stain. Knots, small checks (cracks) and weathering are naturally occurring and do not affect the strength of the product. Annual application of a water-based water repellent sealant or stain is important and will help reduce weathering and checks.

www.yardistrystructures.com

Questions?

Call toll free or write us at:

1 (888) 509-4382

info@yardistrystructures.com

Patents Pending

Limited Warranty

Yardistry warrants that this product is free from defect in materials and workmanship for a period of one year from the original date of purchase. In addition, all lumber is warranted for 5 years against rot and decay. This warranty applies to the original owner and registrant and is non-transferable.

Regular maintenance is required to assure the integrity of your product and is a requirement of the warranty. This warranty does not cover any inspection cost.

This Limited Warranty does not cover:

- Labor for replacement of any defective item(s);
- Incidental or consequential damages;
- Cosmetic defects which do not affect performance or integrity;
- Vandalism; improper use or installation; acts of nature;
- Acts of nature including but not limited to wind, storms, hail, floods, excessive water exposure;
- Minor twisting, warping, checking, or any other natural occurring properties of wood that do not affect performance or integrity.

Yardistry products have been designed for safety and quality. Any modifications made to the original product could damage the structural integrity of the product leading to failure and possible injury. Yardistry cannot assume any responsibility for modified products. Furthermore, modification voids any and all warranties.

This product is warranted for RESIDENTIAL USE ONLY. Yardistry disclaims all other representations and warranties of any kind, express or implied.

This Warranty gives you specific legal rights. You may have other rights as well which vary from state to state or province to province. This warranty excludes all consequential damages, however, some states do not allow the limitation or exclusion of consequential damages, and therefore this limitation may not apply to you.

Instructions for Proper Maintenance

Your Yardistry structure is designed and constructed of quality materials. As with all outdoor products it will weather and wear. To maximize the enjoyment, safety and life of your structure it is important that you, the owner, properly maintain it.

HARDWARE:

- Check metal parts for rust. If found, sand and repaint using a non-lead paint complying with 16 CFR 1303.
- Inspect and tighten all hardware after completion of assembly; after first month of use; and then annually. Do not over-tighten as to cause crushing and splintering of wood.
- Check for sharp edges or protruding screw threads, add washers if required.

WOOD PARTS:

- Applying a water repellent or stain (water-based) on a yearly basis is important maintenance to maintain maximum life and performance of the product.
- Check all wood members for deterioration, structural damage and splintering. Sand down splinters and replace deteriorated wood members. As with all wood, some checking and small cracks in grain is normal
- Some gapping may occur at some wood connections.

Assembly Guides

Tools Required:

- | | | |
|----------------------------------|------------------|---------------------------|
| • Tape Measure | • 8' Step Ladder | • Square |
| • Carpenters Level | • Safety Glasses | • Ratchet |
| • Standard or Cordless Drill | • Adult Helper | • 7/16, 1/2 & 9/16 Socket |
| • Mitre Box or Mitre Saw | • Safety Gloves | |
| • #2 Phillips Bit or Screwdriver | • Hard Hat | |
| • 7/16" & 9/16" Wrench | | |

Symbols:

Throughout these instructions symbols are provided in the top, right-hand corner of the page.



- Use Help, where this is shown, 2, 3 or 4 people are required to safely complete this step. To avoid injury or damage to the assembly make sure to get some help.



- Use a measuring tape to assure proper location



- Pre-drill a pilot hole before fastening screw or lag to prevent splitting of wood.

If you dispose of your Yardistry structure: Please disassemble and dispose of your unit so that it does not create any unreasonable hazards at the time it is discarded. Be sure to follow your local waste ordinances.

Material List

(1) 2 x 6 x 80 1/8" Y50100-024



(2) 2 x 6 x 71 5/8" Y50100-023

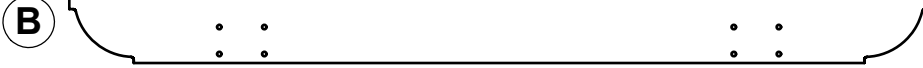

(9) 5/4 x 4 x 59 3/4" Y50100-025

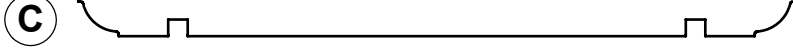

(4) 2 x 2 x 40" Y50100-026

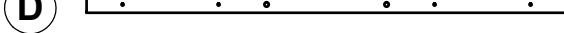

(2) 2 x 6 x 21 5/8" Y50100-022



(1) 1 x 6 x 11" Y50100-019



(2) 2 x 6 x 16 3/4" Y50100-021

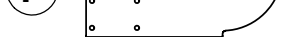

(4) 2 x 6 x 13 1/2" Y50100-020



(2) 2 x 6 x 66 5/8" Y50100-027

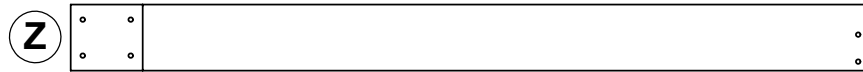

| Nominal | Actual |
|---------|----------------|
| 1 x 6 | 5/8 x 5 3/8" |
| 5/4 x 4 | 1 x 3 1/2" |
| 2 x 2 | 1 1/2 x 1 1/2" |
| 2 x 6 | 1 1/2 x 5 1/2" |
| 4 x 4 | 3 1/2 x 3 1/2" |

H0

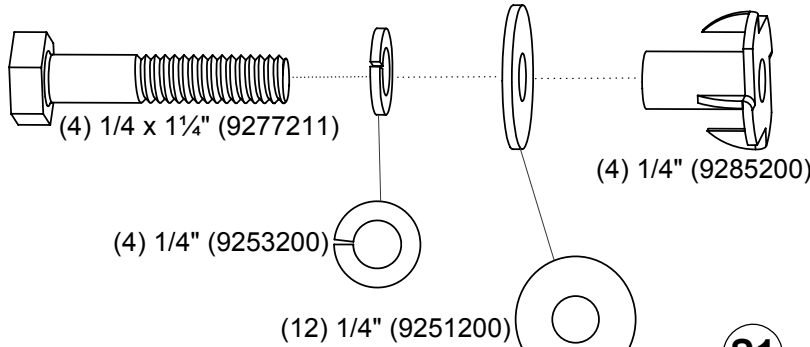

S1

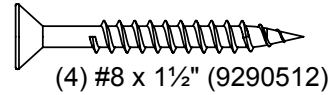

2 1/2

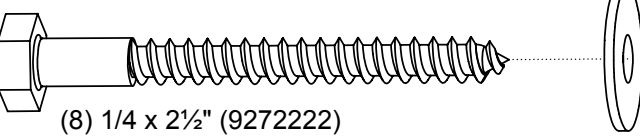

S2

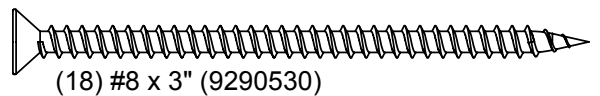

S3

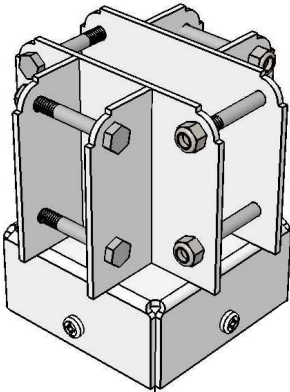
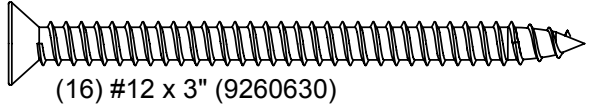

**(6) Post Top Connector With
WH 7/16" Hex Bolt Assembly**

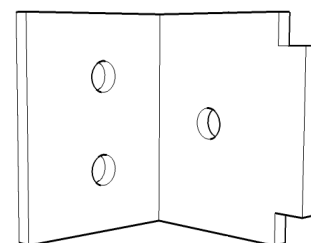

(30) Panel Clips

Material List

FG

(10) Three High Faux Glass Panel

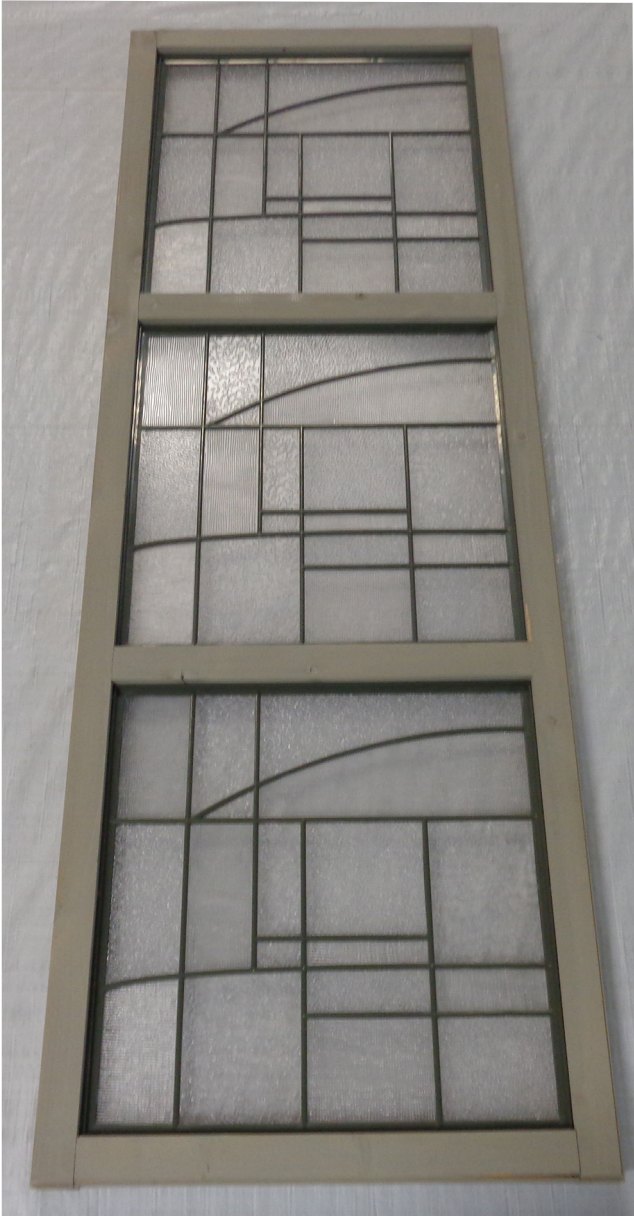

P

R

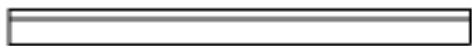

(10) Top and Bottom Rail
(Lengths Vary)

S4



#8 x 2 1/4" Wood Screw

(6) 4x4 Post

S5



#10 x 1" Pan Head Screw

S6



#10 x 1 1/2" Pan Head Screw

S7



#8 x 1 1/2" Wood Screw

Inventory Parts - Read This Before Starting Assembly

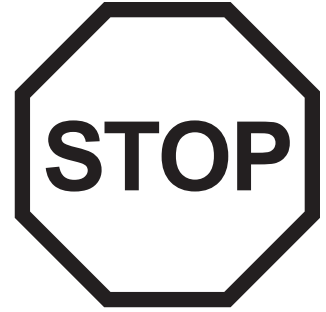
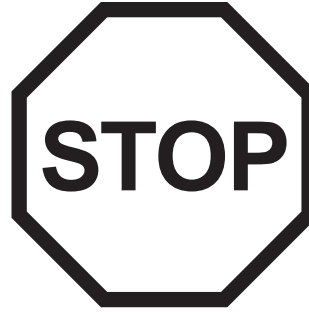

- A.** This is the time for you to inventory all your hardware, wood and accessories, referencing the parts identification sheets. This will assist you with your assembly.
- Each step indicates which bolts and/or screws you will need for assembly, as well as any flat washers, lock washers, t-nuts or lock nuts.
- B.** If there are any missing or damaged pieces or you need assistance with assembly please contact the consumer relations department directly. Call us before going back to the store.

1-888-509-4382

support@yardistrystructures.com

- C.** Read the assembly manual completely, paying special attention to ANSI warnings; notes; and safety/maintenance information on pages 1 - 4.
- Follow the instructions in order.
 - This structure is designed to be assembled and installed ideally by two people, DO NOT attempt to install alone.
 - Consider the slope of elevation where you plan to install the structure. Also, check for gas, telephone, other utilities or sprinkler line locations prior to excavating any holes.
- D.** Before you discard your cartons fill out the form below.
- The carton I.D. stamp is located on the end of each carton.
 - Please retain this information for future reference. You will need this information if you contact the Consumer Relations Department.

PRODUCT NUMBER: YM14126

CARTON I.D. STAMP: ___ ___ ___ ___ ___ (Box 1)

CARTON I.D. STAMP: ___ ___ ___ ___ ___ (Box 2)

CARTON I.D. STAMP: ___ ___ ___ ___ ___ (Box 3)

CARTON I.D. STAMP: ___ ___ ___ ___ ___ (Box 4)

Step 1- Assemble Main Wall



Fig. 1



1. Assemble panels together in configuration shown. (Fig.1). Ensure panels are flush along the bottom then secure panels together with 9 (S4) #8 x 2 1/4" wood screws.

2. Secure R-Top and Bottom Rail to the bottom of the Panel Assembly with 8 (S4) #8 x 2 1/4" Wood Screws in locations indicated by arrows in the direction of the arrow. (Fig. 2)

3. Flip Panel assembly over so orientation of Faux Glass Panels matches Figure 3. Attach R- Top and Bottom Rail to top of the assembly with 4 (S4) #8 x 2 1/4" wood screws in the locations indicated by arrows in the direction of the arrow.

Fig. 2



***R- Top and Bottom Rails will overhang 1/4" on either side of panel.**

***R- Top and Bottom Rails may need to be cut to 6' 6 1/2" (2m)**

(It is recommended to use a Mitre Box or Mitre Saw)

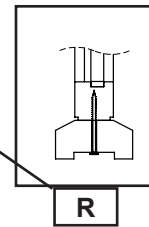
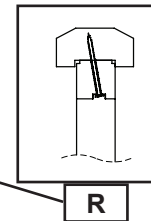

Fig. 3



2 X **R** TOP & BOTTOM RAIL AT 6' 6 1/2"

21 X **S4** #8- 2 1/4" WOOD SCREWS

4 X **FG** FAUX GLASS PANEL

Step 2- Assemble Side Wall



Fig. 1



1. Assemble panels together in configuration shown. (Fig.1)
2. Secure Panels with 3 (S4) #8 x 2 1/4" wood screws provided in pre-drilled holes as indicated by the circles. (Fig.1)
3. Secure R-Top and Bottom Rail to Panel Assembly with 4 (S4) #8 x 2 1/4" Wood Screws locations indicated by the circles (Fig. 2)
4. Flip Panel assembly over so orientation of Faux Glass Panels matches Figure 3. Attach R- Top and Bottom Rail to top of the assembly with 2 (S4) #8 x 2 1/4" wood screws in the locations indicated by arrows in the direction of the arrow.
5. Repeat to create 2 Side Wall Assemblies.

***R- Top and Bottom Rails will overhang 1/4" on either side of panel.**

****R- Top and Bottom Rails may need to be cut to size indicated in material list below.**

(It is recommended to use a Mitre Box or Mitre Saw)

Fig. 2



Fig. 3



4 X **R** TOP & BOTTOM RAIL AT 3' 3 1/2"
4 X **FG** FAUX GLASS PANEL

18 X **S4** #8- 2 1/4" WOOD SCREWS

Step 3- Assemble Single Panel



Fig. 1



1. Secure R-Top and Bottom Rail to bottom of single Panel with 2 (S4) #8 x 2 1/4" Wood Screws locations indicated by the circles (Fig. 1)

2. Flip Panel assembly over so orientation of Faux Glass Panels matches Figure 2. Attach R- Top and Bottom Rail to top of the assembly with 1 (S4) #8 x 2 1/4" wood screw in the locations indicated by the arrow in the direction of the arrow.

3. Repeat for a second Single Panel Assembly.

R- Top and Bottom Rails will overhang 1/4" on either side of panel.

**** R- Top and Bottom Rails may need to be cut to size indicated in material list below.**

(It is recommended to use a Mitre Box or Mitre Saw)

Fig. 2

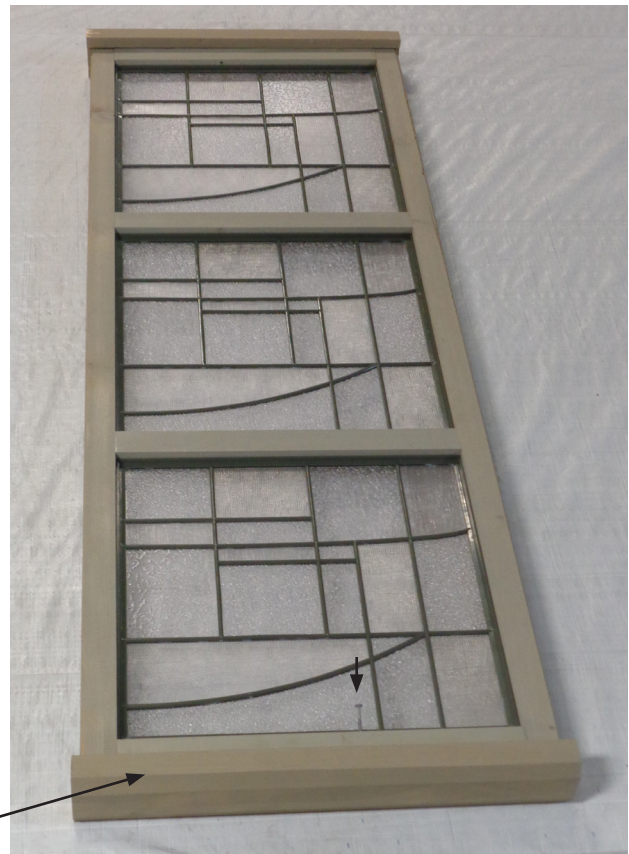

4 X **R** TOP & BOTTOM RAIL AT 20"

6 X **S4** #8- 2 1/4" WOOD SCREWS

2 X **FG** FAUX GLASS PANEL

Step 4 - Attach Panel Clips to Back Posts

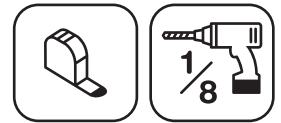

1. On a flat surface place P- 4x4 Post on its side and position Panel Clips in locations indicated in Figures 1 and 1A. **Ensure Panel Clips are oriented as shown in Diagrams!**
2. Panel Clips should be placed in the centre of the post or the leading edge of the clip should be 1 3/8" or 3.5cm away from the side of the post as shown in Fig. 2.
3. With Panel Clips in place, mark screw holes with a pencil and pre-drill holes with a 1/8" drill bit. (Not provided)
4. Secure Panel Clips in locations indicated in figure 1 and 1A with S7- #8 x 1 1/2" wood screws.

Fig. 2

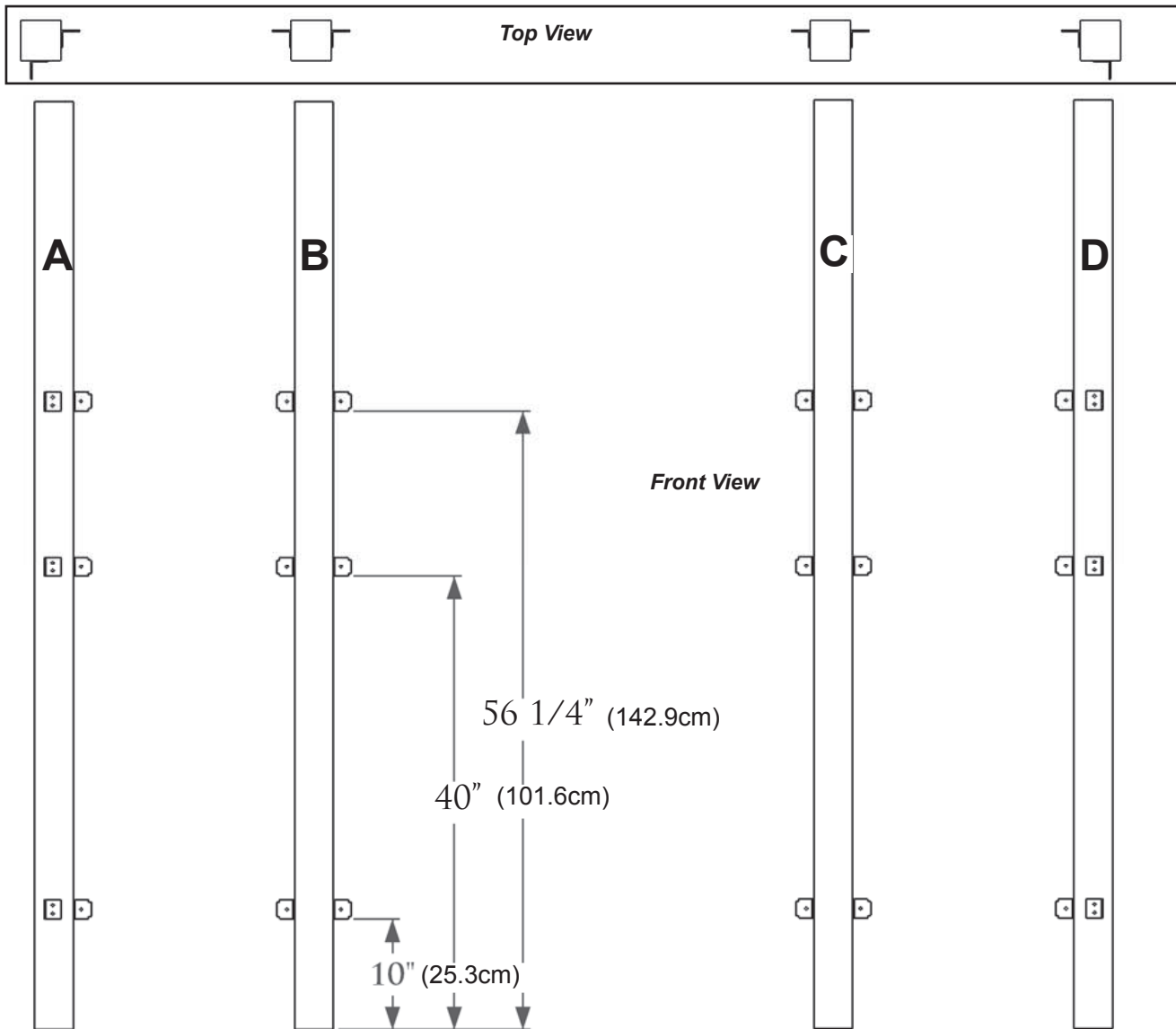
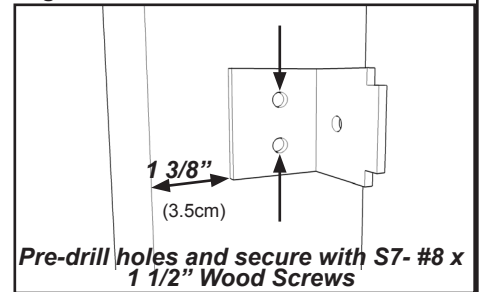

4X 4X4 POST

24X - PANEL CLIPS

48X #8 X 1 1/2" WOOD SCREW

Step 5 - Attach Panel Clips to Side Posts

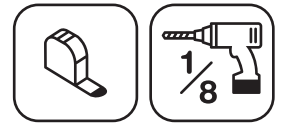

1. On a flat surface place P- 4x4 Post on its side and position Panel Clips in locations indicated in Figures 1 and 1A. **Ensure Panel Clips are oriented as shown in Diagrams! Use posts A and D from previous step.**
2. Panel Clips should be placed in the centre of the post or the leading edge of the clip should be 1 3/8" or 3.5cm away from the side of the post as shown in Fig. 2.
3. With Panel Clips in place, mark screw holes with a pencil and pre-drill holes with a 1/8" drill bit. (Not provided)
4. Secure Panel Clips in locations indicated in figure 1 and 1A with S7- #8 x 1 1/2" wood screws.
5. Repeat for each post configuration.

Fig. 2

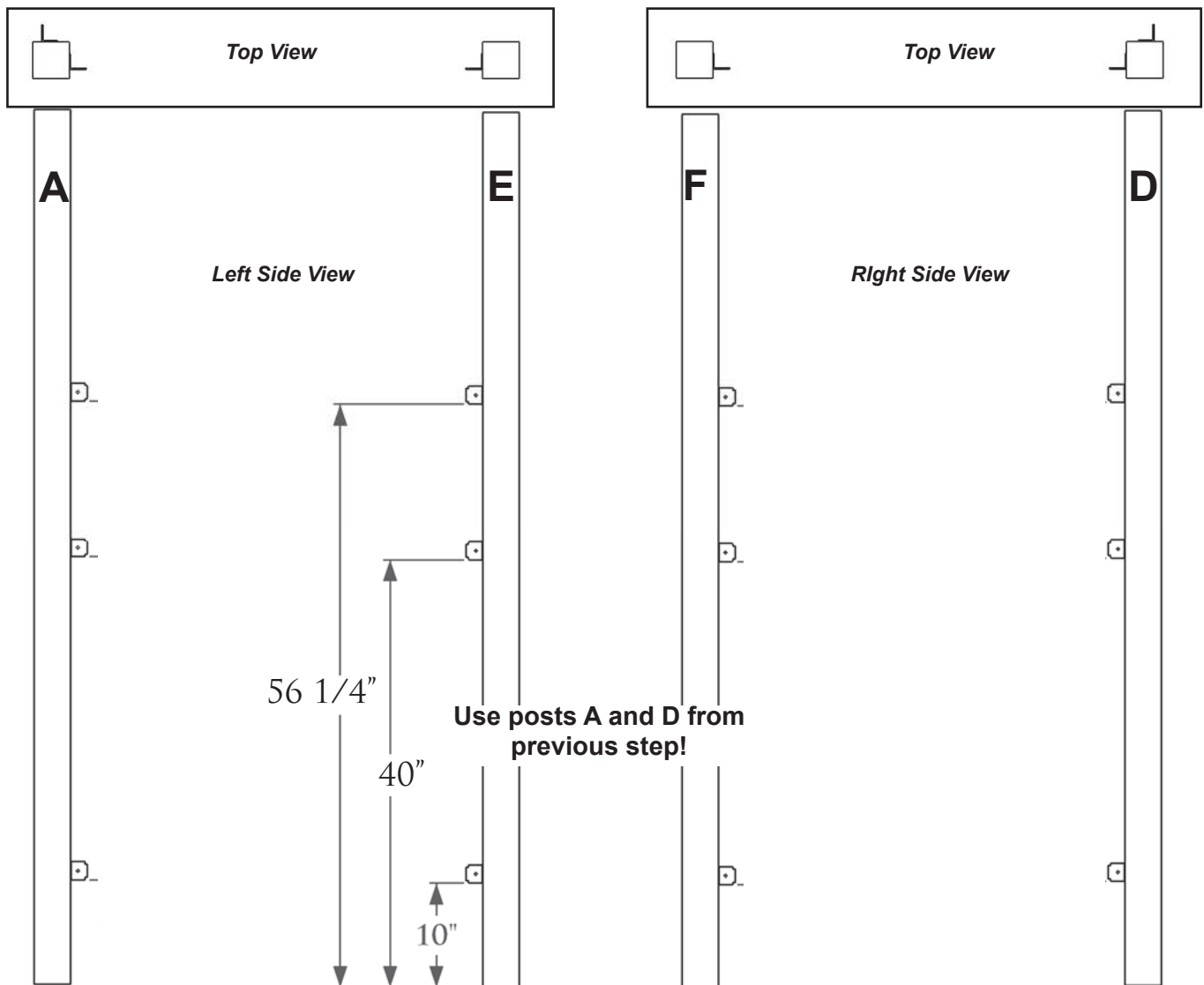
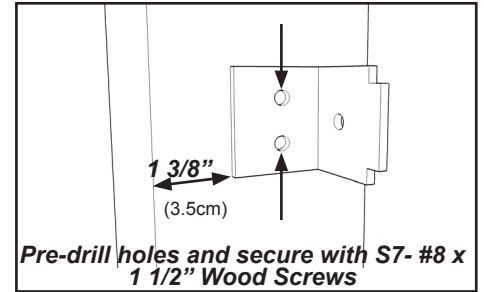

2X **P** 4X4 POSTS

6X - PANEL CLIPS

12X **S7** #8 X 1 1/2" WOOD SCREW

Step 6- Attach Panels to Posts



NOTE: Panel type may not be as shown

1. Place panel assemblies on posts as shown (Fig.1) allowing a 4" gap between the bottom of the post and the bottom edge of the bottom rail on the panel assembly. *Note: Assemble with the help of another adult!*
2. With a 1/8" drill bit, predrill holes as shown in Figure 2.
3. Fasten the panel assemblies to the post and Panel Clips with a (S5) #10 x 1" Pan Head Screw provided in location of circles. (Fig. 1)

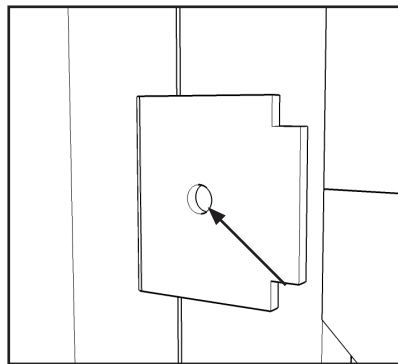
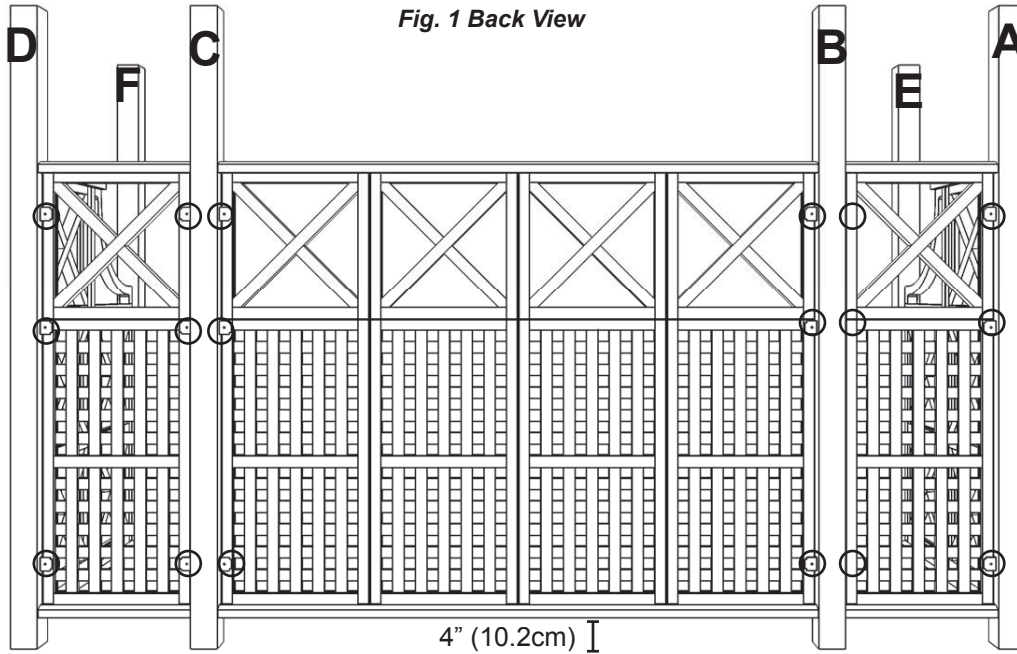

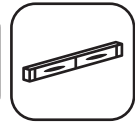
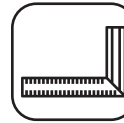

Fig. 2. Predrill Holes and Fasten with S5- 1" Pan Head Screw

12 X  4X4 POST

30 X  #10 X 1" PAN SCREWS

Step 7- Layout Posts and Connectors



NOTE: Panel type may not be as shown

1. Layout pergola bases in configuration shown in figure 1. ***Posts must be securely installed to support structure. Consult local building codes and ground conditions for required footing design. It is recommended the structure be secured to existing stone, concrete or deck with appropriate hardware. Mounting hardware not provided as surfaces may vary.**
2. Install Post Top Connectors with (S6) #10 x 1- 1/2" Pan Head Screws provided. (Fig. 2) Ensure the direction of the Post Top Connector is the same direction as indicated by the arrows in figure 1.

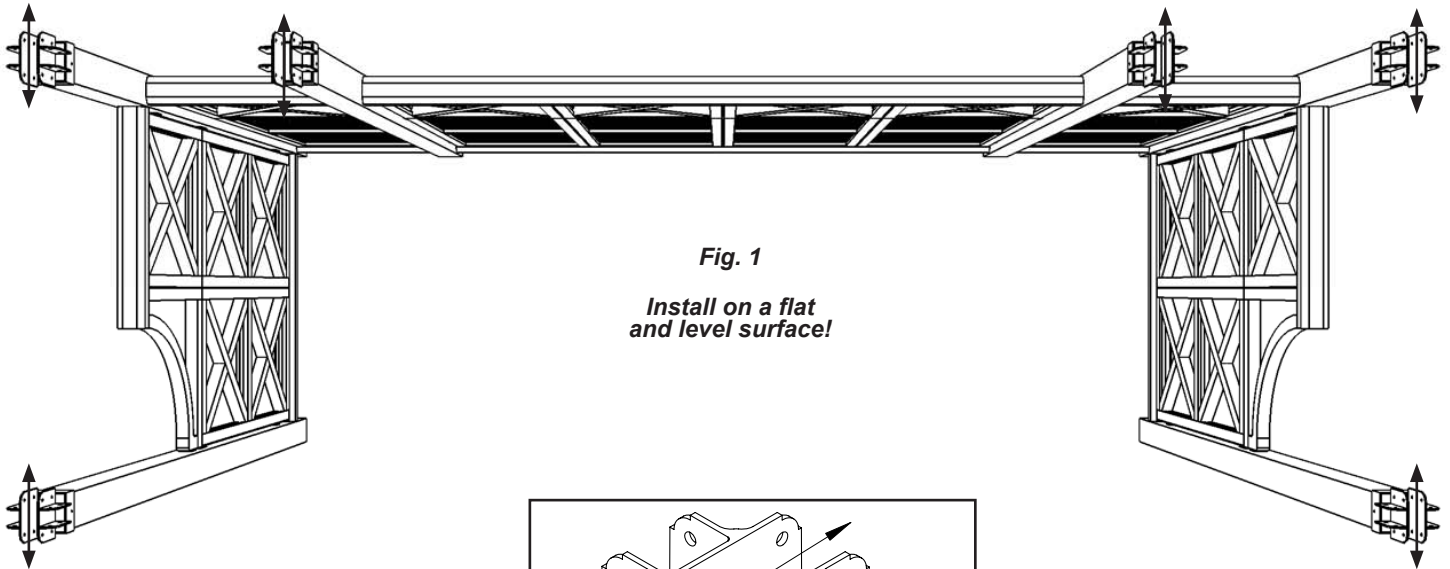
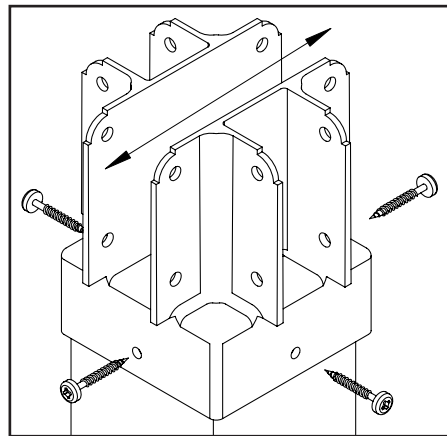



Fig. 1
**Install on a flat
and level surface!**

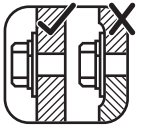

**Fig. 2 - Attach Post Top Connectors with
(S6)- #10 x 1 1/2" Pan Head Screws.**

24X  #10 X 1 1/2" PAN HEAD SCREWS

6X - POST TOP CONNECTOR

Step 8- Assemble Front and Back Beams



1. Secure two Z-2 x 6 x 66 5/8" Beams together with (H0) 1/4" x 1 1/4" Hex Bolts as shown in Figure 1.
2. Attach Y-1 x 6 x 11" Plaque with (S1) #8 - 1 1/2" Wood Screws as shown in Fig. 1.
3. Complete Z- Front Beam by securing two Z-2 x 6 x 66 5/8" Beams and two D-2 x 2 x 40" Brace with 1/4 x 2 1/2" Hex Lag Bolt and (S3) #12 x 3" Wood Screws as shown in Figure 1. **Note: Hex Lag Bolt assembly in diagram below.**
4. Assemble A- Back Beam by attaching one A-2 x 6 x 80 1/8" Beam and two D-2 x 2 x 40" Brace with 1/4 x 2 1/2" Hex Lag Bolt and (S3) #12 x 3" Wood Screws as shown. **Note: Hex Lag Bolt assembly in diagram below.**

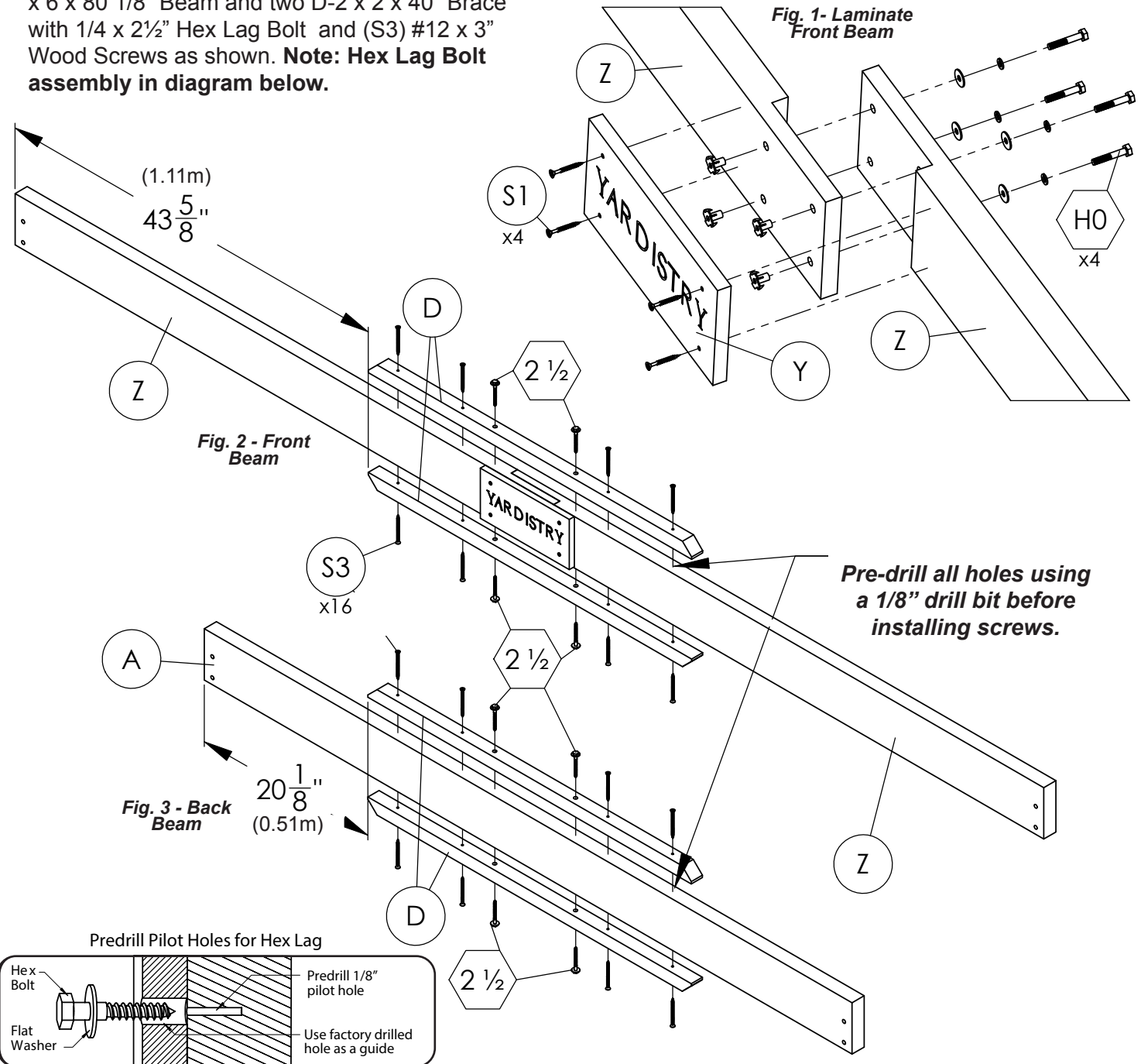

| | | |
|--|-------------------------------------|--------------------------|
| 8X 1/4 X 2 1/2" HEX LAG BOLT W/ WASHERS | 4X 1/4" X 1 1/4" HEX BOLT ASSEMBLY | 1X 2 X 6 X 80 1/8" BEAM |
| 16X #12- 3" WOOD SCREW | | 4X 2 X 2 X 40" BRACE |
| 4X #8- 1 1/2" WOOD SCREW | 2X 2 X 6 X 66 5/8" BEAM | 1X 1 X 6 X 11" PLAQUE |

Step 9 - Mounting Beams to Connectors

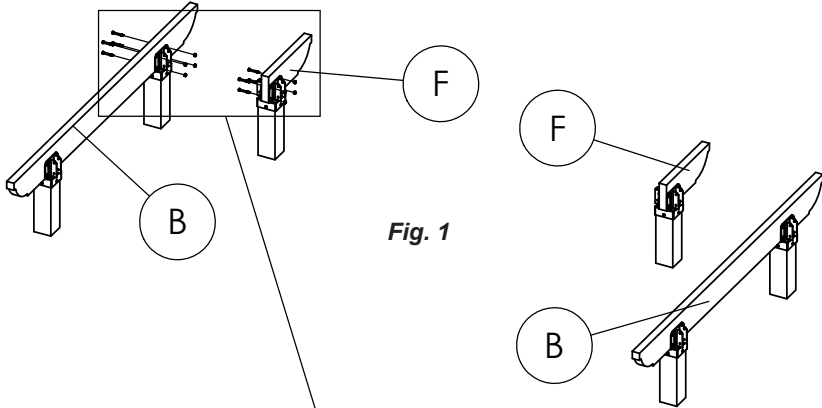
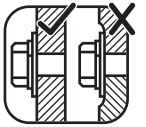

Fig. 1

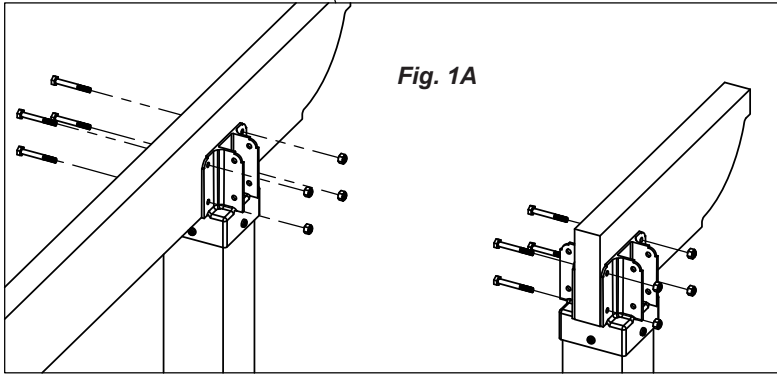

Fig. 1A

1. Attach two B- 2 x 6 x 71 5/8" Beams to Post Top Connectors with (WH) 7/16" Hex Bolt as shown in Fig. 1 and 1A.
2. Attach two F- 2 x 6 x 16 3/4" Beam Ends to Post Top Connectors with (WH) 7/16" Hex Bolt as shown in Fig. 1 and 1A.
3. Attach one A- Back Beam and one Z- Front Beam to Post Top Connectors with (WH) 7/16" Hex Bolt as shown in Fig. 2 and 2A.
4. Attach four H- 2 x 6 x 13 1/2" Beam Ends to Post Top Connectors with (WH) 7/16" Hex Bolt as shown in Fig. 2 and 2A.
5. Attach two E- 2 x 6 x 21 5/8" Beams to Post Top Connectors with (WH) 7/16" Hex Bolt as shown in Fig. 2 and 2A.

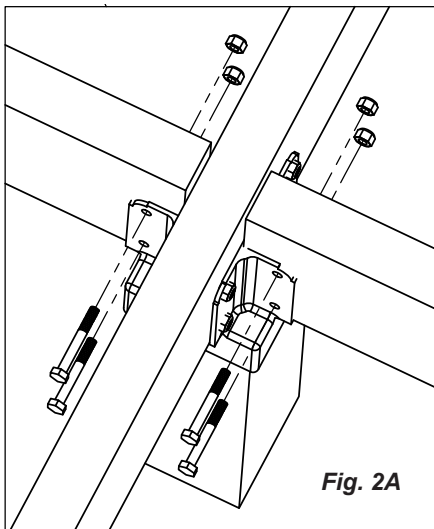

Fig. 2A

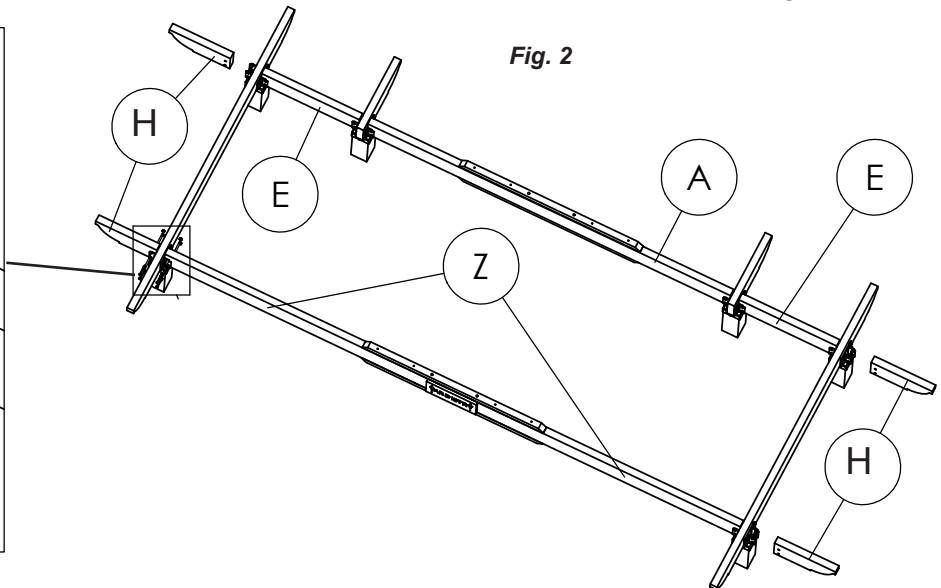

Fig. 2

2X **B** 2 X 6 X 71 5/8" BEAMS

2X **F** 2 X 6 X 16 3/4" BEAM ENDS

4X **H** 2 X 6 X 13 1/2" BEAM ENDS

2X **E** 2 X 6 X 21 5/8" BEAMS

48X **WH** 7/16" HEX BOLT W/ NUT

Step 10- Installing Pergola Roof

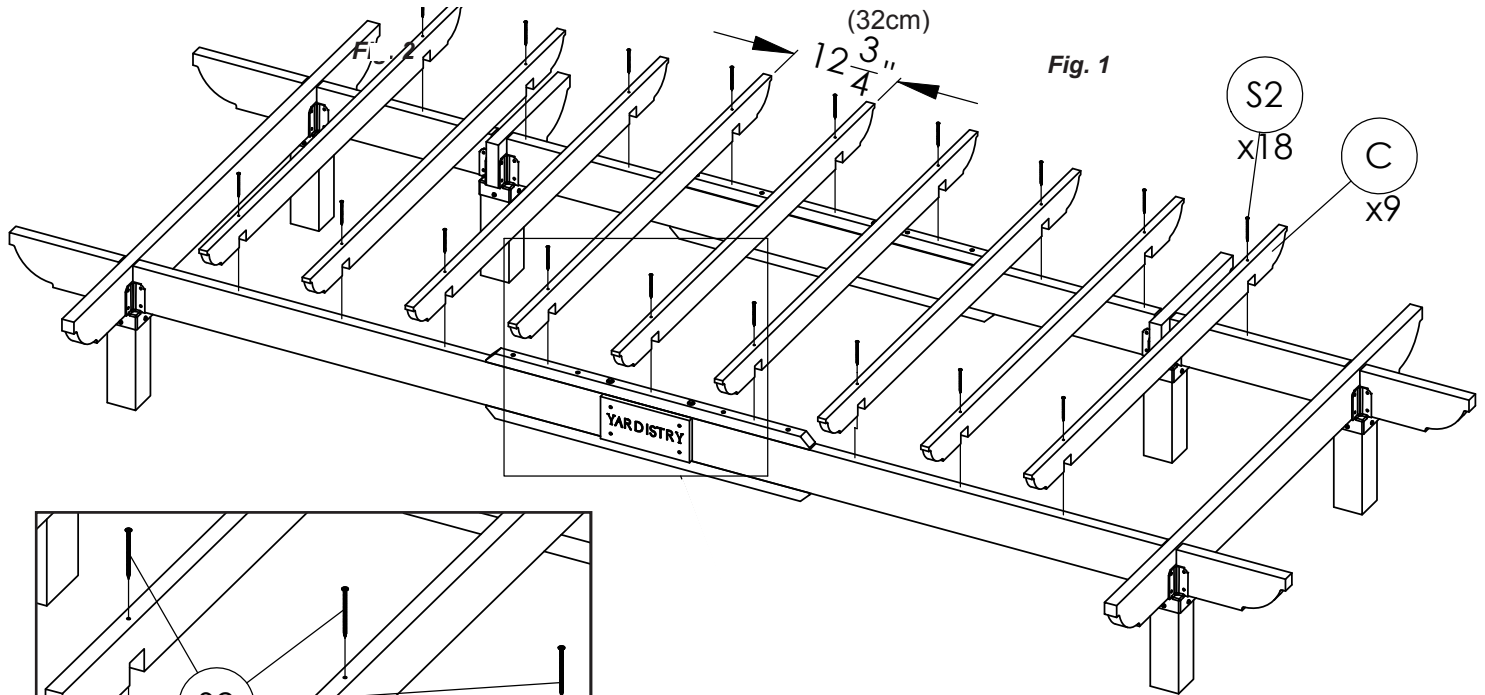
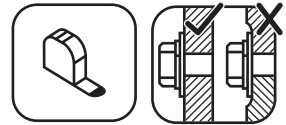

Fig. 1

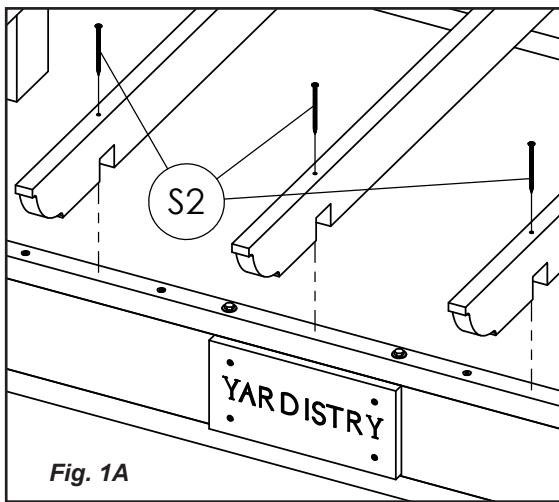
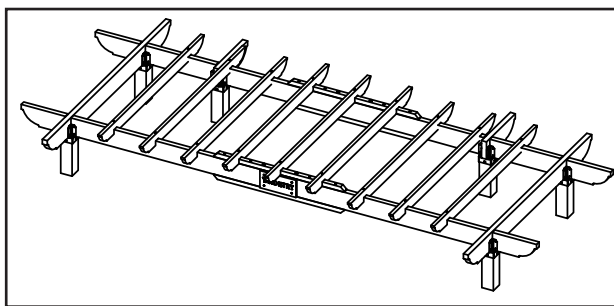

Fig. 1A

1. Layout nine C-5/4 x 4 x 59 3/4" Trellis on the beams, centering the middle beam as shown in figure 1.
2. Allow for a 12 3/4" or 32cm gap between each Trellis. (outside face to outside face)
3. Fasten Trellis roof to beams with (S2) #8 x 3" Wood Screws. Fig. 1 & 1A



9X C 5/4 x 4 x 59 3/4" TRELLIS

18X S2 #8 x 3" WOOD SCREWS



Customer Registration Card - Tarjeta de Registro del Cliente - Carte d'inscription du client

| | | |
|-------------------------------------|------------------------------|---------------------------------------|
| First Name - Primer Nombre - Prénom | Initial - Inicial - Initiale | Last Name - Apellido - Nom de famille |
| | | |

| | | |
|----------------------|---|-----------------|
| Street - Calle - Rue | PO Box - Casilla postal - Boîte postale | Apt. No. - App. |
| | | |

| | |
|-----------------------|---|
| City - Ciudad - Ville | State/Province - Estado/Provincia - État/Province |
| | |

| | |
|---|-----------------------|
| ZIP/Postal Code - Código Postal - ZIP/Code postal | Country - País - Pays |
| | |

| | |
|---|--|
| E-mail Address - Dirección de E-mail - Adresse courriel | Telephone Number - No. de Teléfono - N° de téléphone |
| | |

| | |
|--|--|
| Model Name - Nombre del Modelo - Nom du modèle | Model Number (from front cover) - Número de Modelo (de la portada) - N° du modèle (page de couverture) |
| | |

| | |
|---|---|
| Date of Purchase - Fecha de Compra - Date d'achat (mm/dd/yyyy) (mm/dd/aaaa) (mm/jj/aaaa) | Place of Purchase - Comprado a - Lieu d'achat |
| | |

| |
|--|
| Comments - Comentarios - Commentaires: |
| |
| |
| |

Mail To - Enviar por Correo a - Envoyer par courrier à:

Yardistry
 375 Sligo Road West, PO Box 10
 Mount Forest, Ontario, Canada, N0G 2L0
 Attention: Consumer Relations
 Atención a: Servicio de Atención al Cliente
 À l'attention de: Service à la clientèle

Online Registration - Registro online - Enregistrement en ligne:

<http://yardistrystructures.com/warranty.php>

Yardistry would like to say "Thank you" for your time and feedback.
 Yardistry quiere "Agradecerle" por su tiempo y su opinión.
 Yardistry aimerait vous remercier d'avoir pris le temps de répondre au sondage.