

12 X 14 PERGOLA ROOM

Installation and Operating Instructions – YM12600

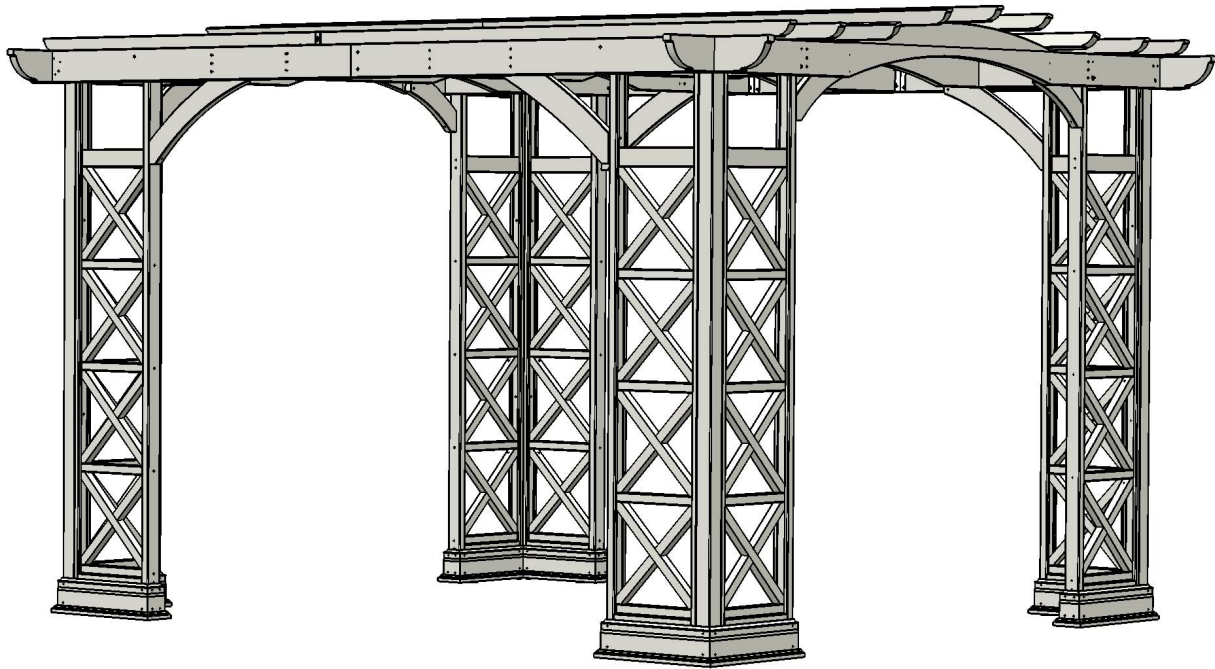

Revised 04/22/2016

YARDISTRY

Yardistry – North America
Toll Free Customer Support: 1.888.509.4382
info@yardistrystructures.com
www.yardistrystructures.com

Yardistry / Selwood Products – Europe
Customer Support: +44 1284 852569
parts@selwoodproducts.com
www.selwoodproducts.com

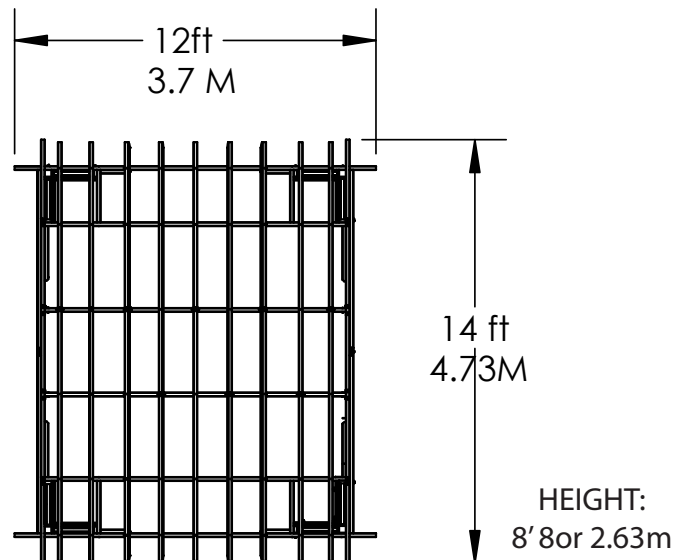

Important Safety Notice!

Yardistry components are intended for privacy, decorative and ornamental use only.

Product is NOT INTENDED for the following:

- A safety barrier to prevent unsupervised access to pools, hot tubs, spas or ponds.
- As load bearing support for a building, structure, heavy objects or swings.
- Used in structures that trap wind, rain or snow that would create extra load on the product.

Permanent structures may require a building permit. As the purchaser and or installer of this product you are advised to consult local planning, zoning and building inspection departments for guidance on applicable building codes and/or zoning requirements.

Wood is NOT flame retardant and will burn. Grills, fire pits and chimineas are a fire hazard if placed too close to a Yardistry structure. Consult user's manual of the grill, fire pit or chiminea for safe distances from combustible materials.

Wear gloves to avoid injury from possible sharp edges of individual elements before assembly.

During installation, follow all safety warnings provided with your tools and use OSHA approved safety glasses. Some structures may require two or more people to install safely.

Check for underground utilities before digging or driving stakes into the ground!

General Information

General Information: Wood components are manufactured with Cedar (C. Lanceolata) which is protected with factory applied water-based stain. Knots, small checks (cracks) and weathering are naturally occurring and do not affect the strength of the product. Annual application of a water-based water repellent sealant or stain will help reduce weathering and checks.

www.yardistrystructures.com

Questions?

Call toll free or write us at:

1 (888) 509-4382

info@yardistrystructures.com

Patents Pending

Limited Warranty

Yardistry warrants that this product is free from defect in materials and workmanship for a period of one year from the original date of purchase. In addition, all lumber is warranted for 5 years against rot and decay. This warranty applies to the original owner and registrant and is non-transferable.

Regular maintenance is required to assure the integrity of your product and is a requirement of the warranty. This warranty does not cover any inspection cost.

This Limited Warranty does not cover:

- Labor for replacement of any defective item(s);
- Incidental or consequential damages;
- Cosmetic defects which do not affect performance or integrity;
- Vandalism; improper use or installation; acts of nature;
- Acts of nature including but not limited to wind, storms, hail, floods, excessive water exposure;
- Minor twisting, warping, checking, or any other natural occurring properties of wood that do not affect performance or integrity.

Yardistry products have been designed for safety and quality. Any modifications made to the original product could damage the structural integrity of the product leading to failure and possible injury. Yardistry cannot assume any responsibility for modified products. Furthermore, modification voids any and all warranties.

This product is warranted for RESIDENTIAL USE ONLY. Yardistry disclaims all other representations and warranties of any kind, express or implied.

This Warranty gives you specific legal rights. You may have other rights as well which vary from state to state or province to province. This warranty excludes all consequential damages, however, some states do not allow the limitation or exclusion of consequential damages, and therefore this limitation may not apply to you.

Instructions for Proper Maintenance

Your Yardistry structure is designed and constructed of quality materials. As with all outdoor products it will weather and wear. To maximize the enjoyment, safety and life of your structure it is important that you, the owner, properly maintain it.

HARDWARE:

- Check metal parts for rust. If found, sand and repaint using a non-lead paint complying with 16 CFR 1303.
- Inspect and tighten all hardware after completion of assembly; after first month of use; and then annually. Do not over-tighten as to cause crushing and splintering of wood.
- Check for sharp edges or protruding screw threads, add washers if required.

WOOD PARTS:

- Unprotected they will appear weathered over time. Periodic application of an exterior water repellent or stain (water-based) will help improve appearance and life.
- Check all wood members for deterioration, structural damage and splintering. Sand down splinters and replace deteriorated wood members. As with all wood, some checking and small cracks in grain is normal

Assembly Guides

Tools Required:

- | | |
|----------------------------------|------------------|
| • Tape Measure | • 8' Step Ladder |
| • Carpenters Level | • Safety Glasses |
| • Standard or Cordless Drill | • Adult Helper |
| • #2 Phillips Bit or Screwdriver | • Gloves |
| • 7/16" Wrench or Socket | • Hard Hat |

Symbols:

Throughout these instructions symbols are provided in the top, right-hand corner of the page.



- Use Help, where this is shown, 2 or 3 people are required to safely complete this step. To avoid injury or damage to the assembly make sure to get some help.



- Use a measuring tape to assure proper location



- Pre-drill a pilot hole before fastening screw or lag to prevent splitting of wood.

If you dispose of your Yardistry structure: Please disassemble and dispose of your unit so that it does not create any unreasonable hazards at the time it is discarded. Be sure to follow your local waste ordinances.

Permanent Installation Examples

Note: It is critically important you start with square, solid and level footings, concrete pad or deck to attach your Pergola Room.

We supply Room L-Mounts with this structure which gives you the flexibility to permanently install your structure to a pre-existing or new wood or concrete surface.

- The hardware to attach the Room L-Mount to the structure is included.
- The hardware to mount the structure permanently will need to be purchased separately at your local hardware store.

If you are mounting to concrete footers see below for the correct locations and placement. Please double check for possibility of any underground utilities such as gas, telephone, cable or sprinkler lines.

Following are some examples of how to mount the structure to wood or concrete surfaces.

Refer to your local building and city codes, ordinances, neighbourhood covenants, or height restrictions regarding this type of structure for guidance on acceptable installation requirements.

Concrete Footer

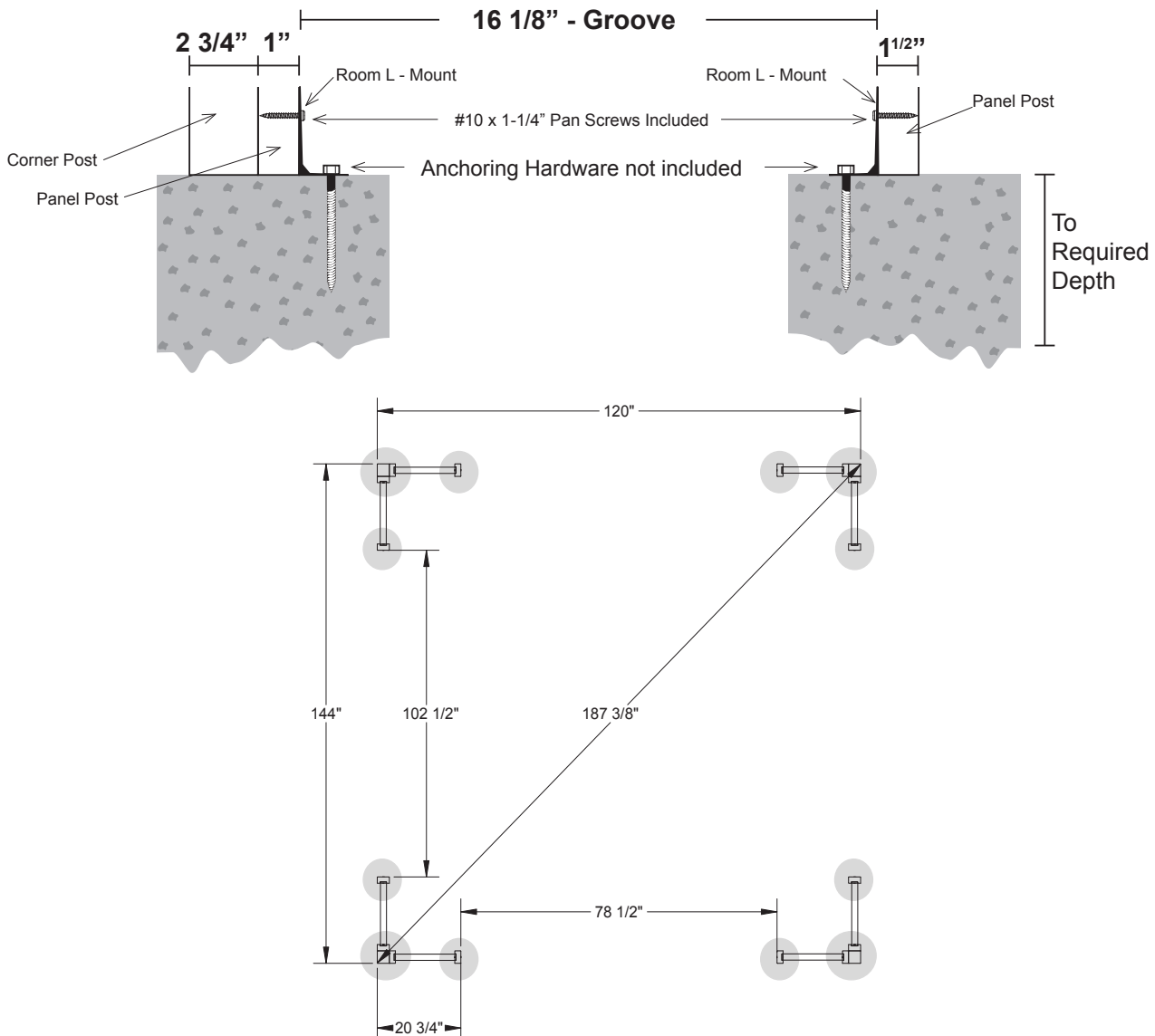

Permanent Installation Examples cont.

Concrete Patio (min. 10' 2" x 10' 2") with 12" clearance on all sides

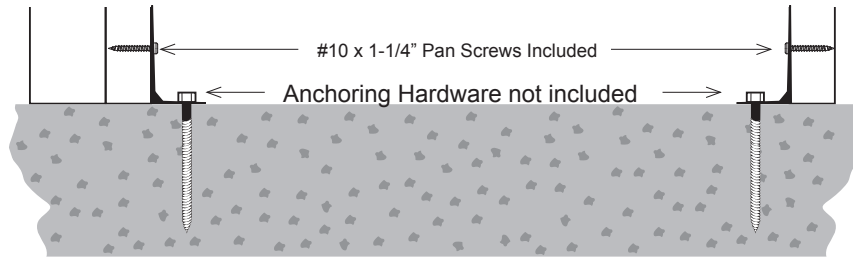

Wood Deck (min. 10' 2" x 10' 2") with 12" clearance on all sides

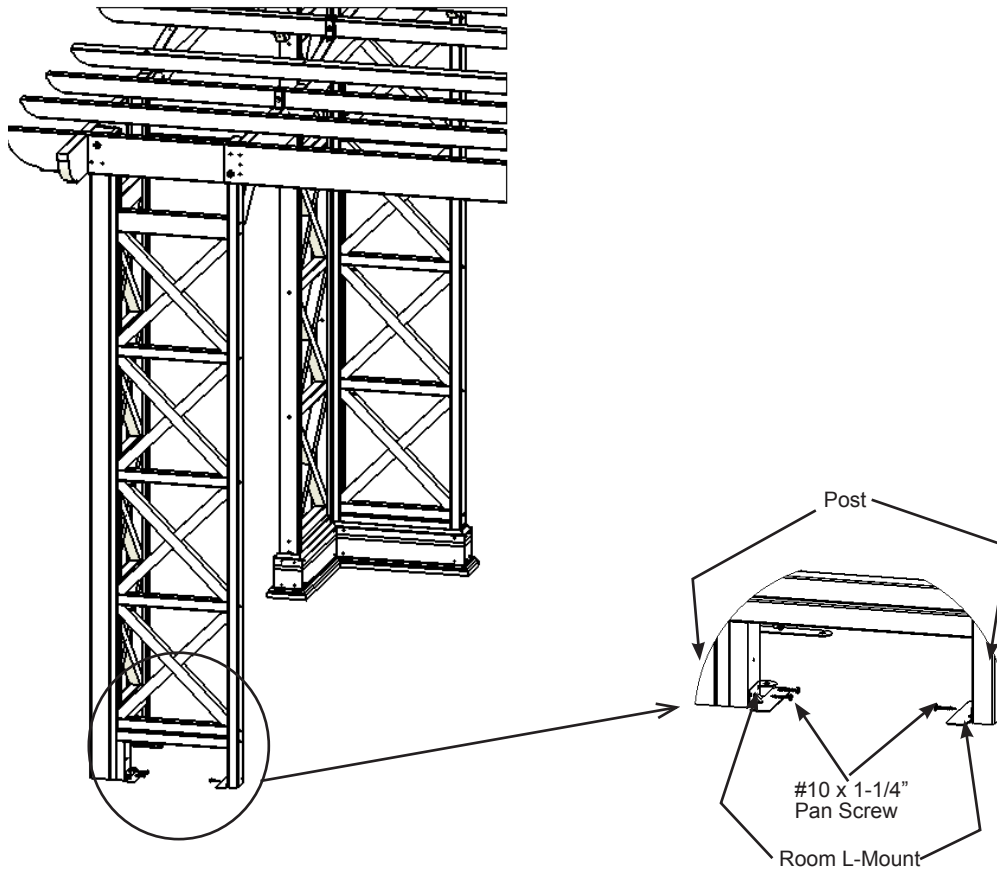
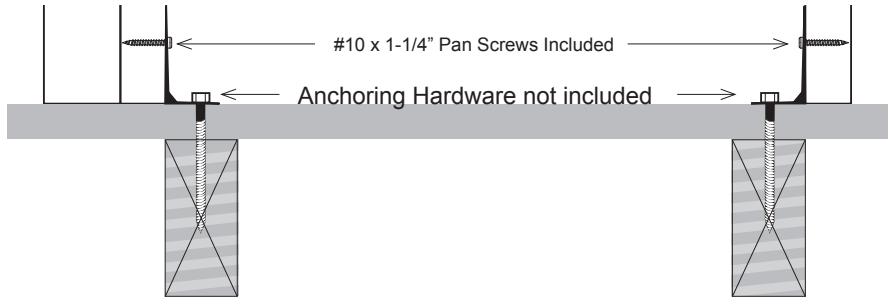

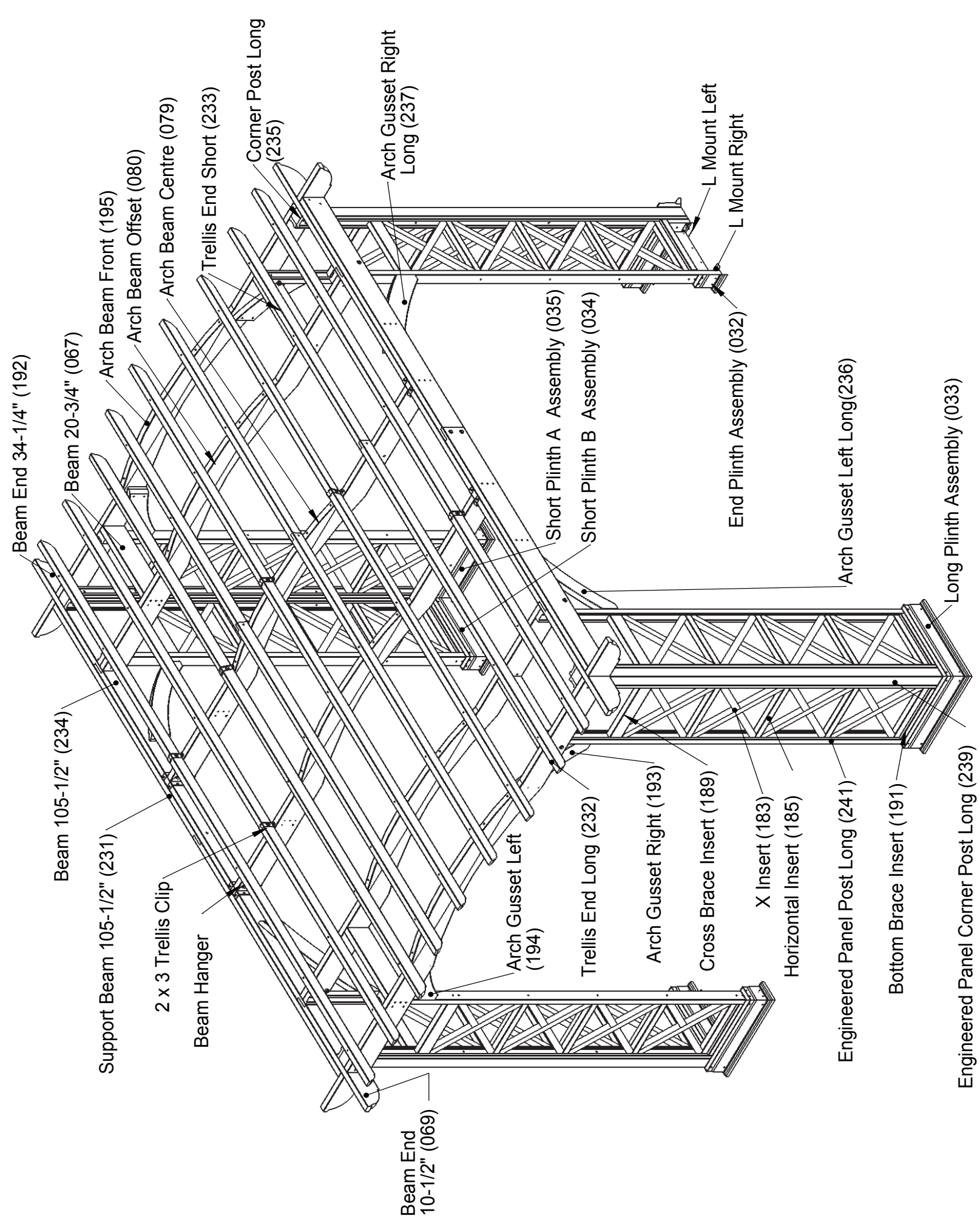

Part Identification (Dimensions are approximate and are shown to assist in the identification of parts for assembly. Actual dimensions may be smaller or larger.)

38.1 x 38.1 x 409.6mm
32pc. (185) - Horizontal Insert 2 x 2 x 16-1/8" - Box 1

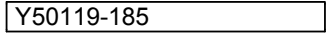

38.1 x 38.1 x 574.7mm
64pc. (183) - X Insert 2 x 2 x 22-5/8" - Box 1,2,3

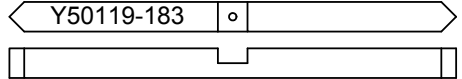

38.1 x 63.5 x 1699.7mm
9pc. (233) - Trellis End Short 2 x 3 x 66 15/16" - Box 2

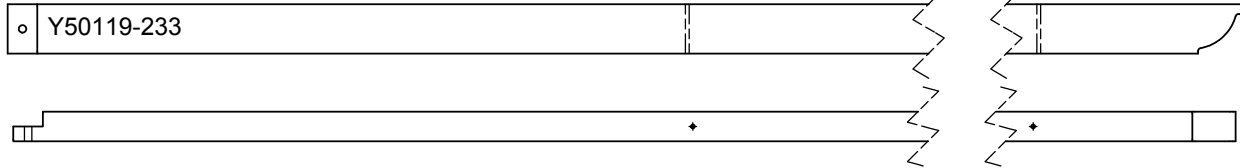

38.1 x 63.5 x 2554.8mm
9pc. (232) - Trellis End Long 2 x 3 x 100 -5/8" - Box 1

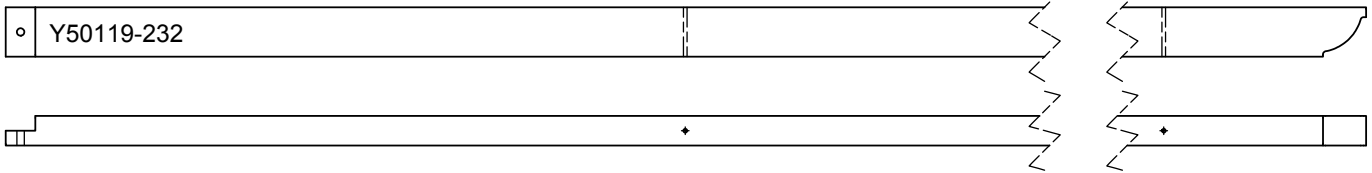

38.1 x 76.2 x 409.6mm
8pc. (189) - Cross Brace Insert 2 x 4 x 16-1/8" - Box 3

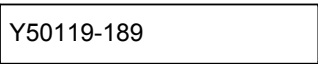

36 x 69.9 x 2463.8mm
8pc. (241) - Engineered Panel Post Long 2 x 4 x 97" - Box 2

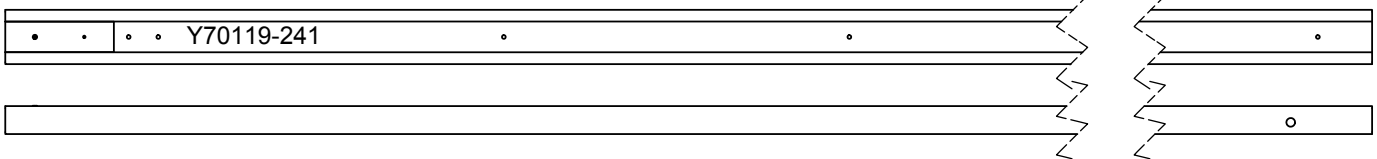

53.5 x 69.9 x 2463.8mm
8pc. (239) - Engineered Panel Corner Post Long 2 x 4 x 97" - Box 2

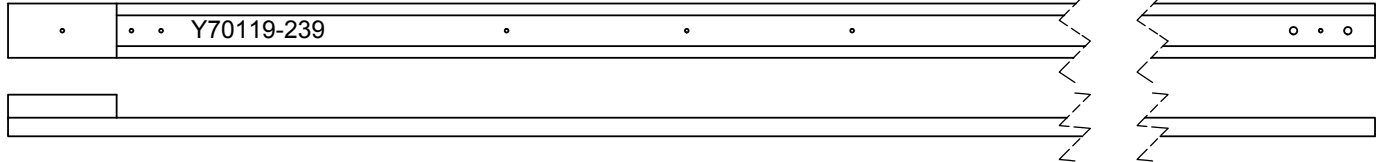

36 x 127 x 453.2mm
2pc. (194) - Arch Gusset Left 2 x 5 x 17-27/32" - Box 3

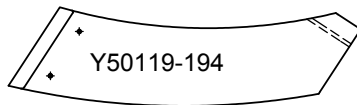

36 x 127 x 453.2mm
2pc. (193) - Arch Gusset Right 2 x 5 x 17-27/32" - Box 3

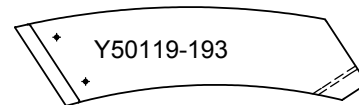

38.1 x 139.7 x 266.7mm
4pc. (069) - Beam End 10-1/2" 2 x 6 x 10-1/2" - Box 3

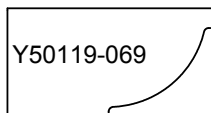

38.1 x 69.9 x 408.9mm
8pc. (191) - Bottom Brace Insert 2 x 4 x 16-1/8" - Box 3

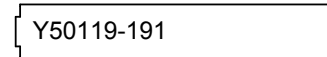

36 x 139.7 x 762mm
2pc. (237) - Arch Gusset Right Long 2 x 6 x 30" - Box 1



36 x 139.7 x 762mm
2pc. (236) - Arch Gusset Left Long 2 x 6 x 30" - Box 1



Part Identification (Dimensions are approximate and are shown to assist in the identification of parts for assembly. Actual dimensions may be smaller or larger.)

38.1 x 139.7 x 527.1mm
4pc. (067) - Beam 20-3/4" 2 x 6 x 20-3/4" - Box 3



38.1 x 139.7 x 870mm
4pc. (192) - Beam End 34-1/4" 2 x 6 x 34-1/4" - Box 3



38.1 x 139.7 x 1866.9mm
4pc. (231) - Support Beam 2 x 6 x 73-1/2" - Box 2



38.1 x 241.3 x 3048.0mm
2pc. (195) - Arch Beam Front - Box 3

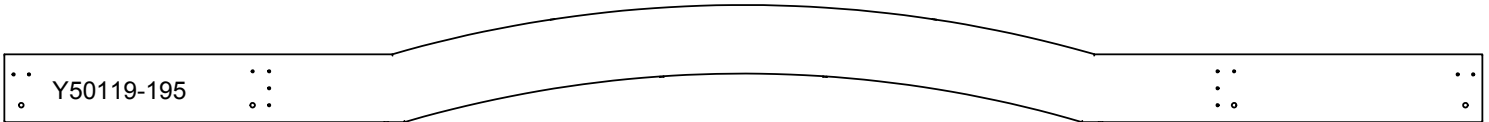

38.1 x 241.3 x 3048.0mm
2pc. (080) - Arch Beam Offset - Box 3

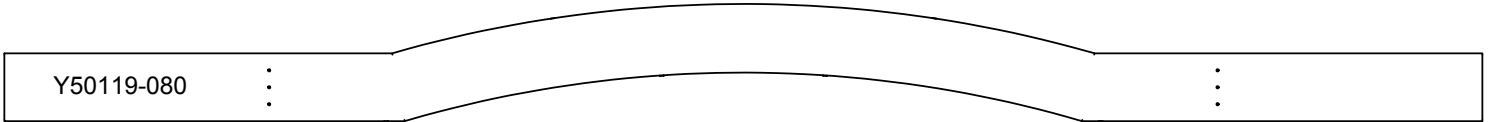

38.1 x 241.3 x 3048.0mm
2pc. (079) - Arch Beam Centre - Box 3

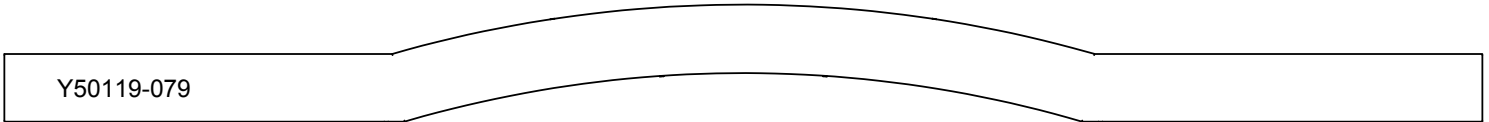

38.1 x 139.7 x 2679.7mm
2pc. (234) - Beam 105-1/2" 2 x 6 x 105-1/2" - Box 1



69.9 x 69.9 x 2463.8mm
4pc. (235) - Corner Post Long 3 x 3 x 97" - Box 2



34.9 x 152.4 x 141.3mm
8pc. (032) - End Plinth Assembly - Box 1

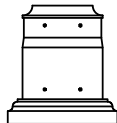

Y70119-032

34.9 x 152.4 x 492.1mm
4pc. (035) - Short Plinth A Assembly - Box 1

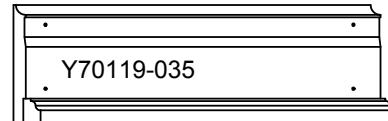

Y70119-035

34.9 x 152.4 x 598.5mm
8pc. (033) - Long Plinth Assembly - Box 1

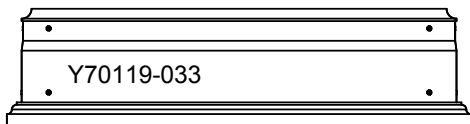

Y70119-033

34.9 x 152.4 x 492.1mm
4pc. (034) - Short Plinth B Assembly - Box 1

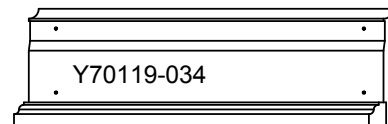

Y70119-034

Hardware Identification (Dimensions are approximate and are shown to assist in the identification of parts for assembly. Actual dimensions may be smaller or larger.)

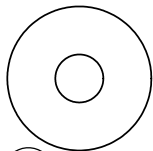
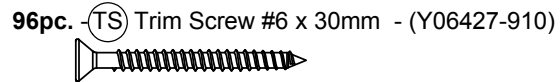
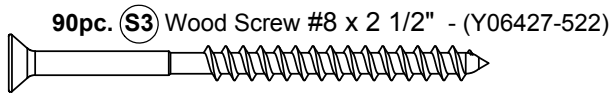
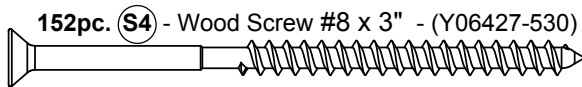
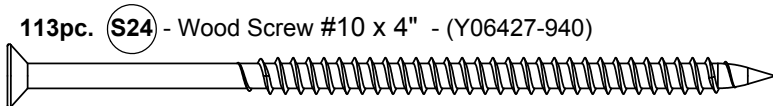
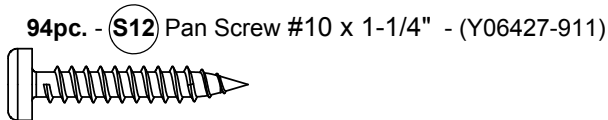
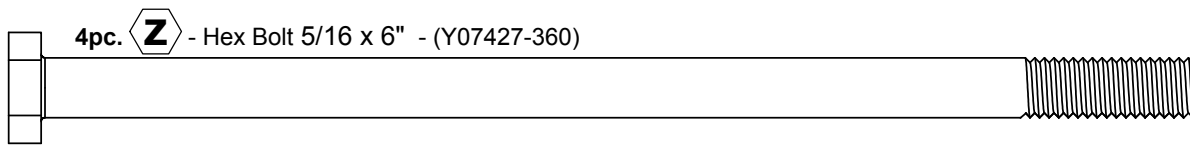
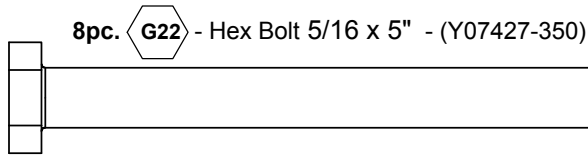
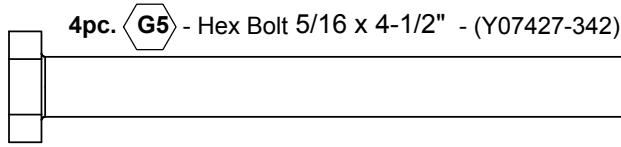
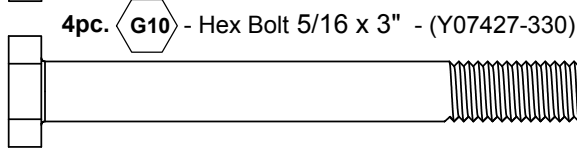
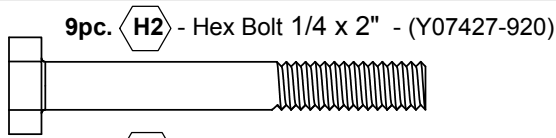

18pc. **FW1** - 1/4" Flat Washer
(Y05427-201)

1pc. **D4** - #2 x 2" Roberston Driver (9200014)

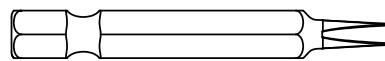

9pc. - 1/4" Lock Nut
(Y08427-203)

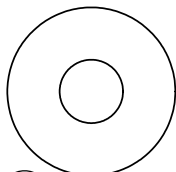
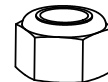

20pc. **FW2** - 5/16" Flat Washer
(Y05427-301)

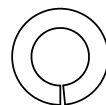

20pc. **LW2** - 5/16" Lock Washer
(Y05427-300)

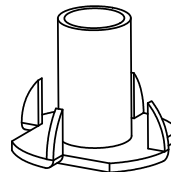

20pc. **TN2** - 5/16 - T-Nut
(Y08427-300)

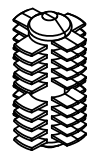

1pc. **YP1** - X Insert Pin
(Y70814-001) (34 PK)

Hardware Identification (Dimensions are approximate and are shown to assist in the identification of parts for assembly. Actual dimensions may be smaller or larger.)

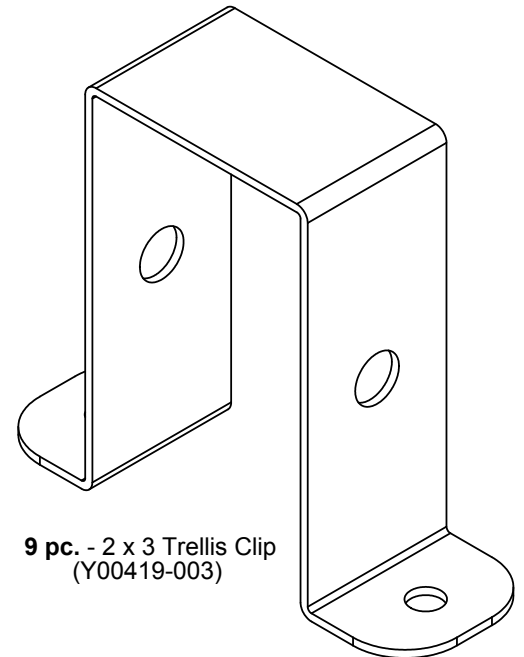
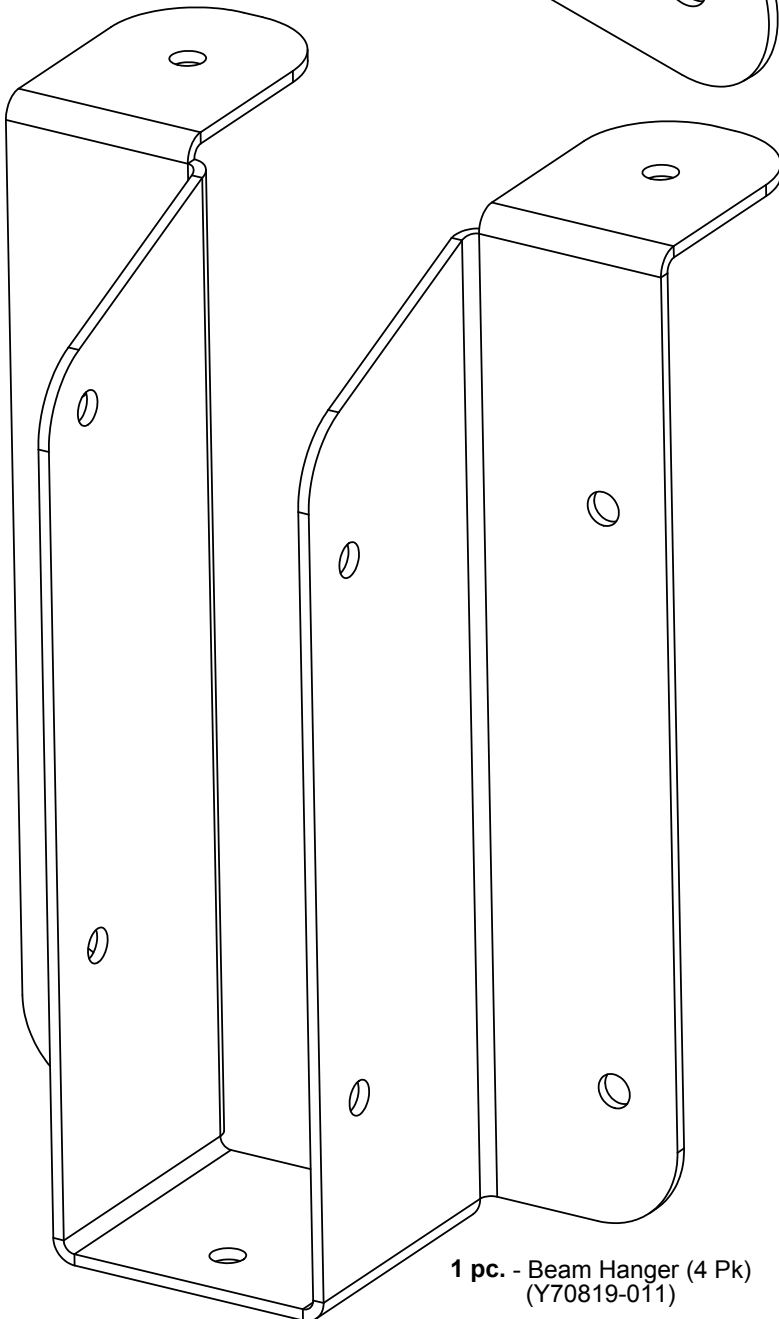
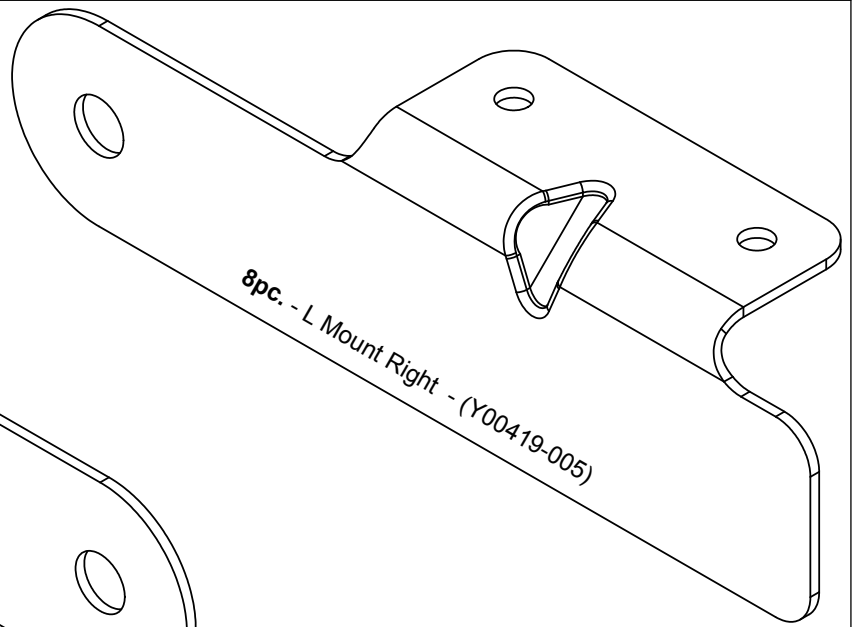
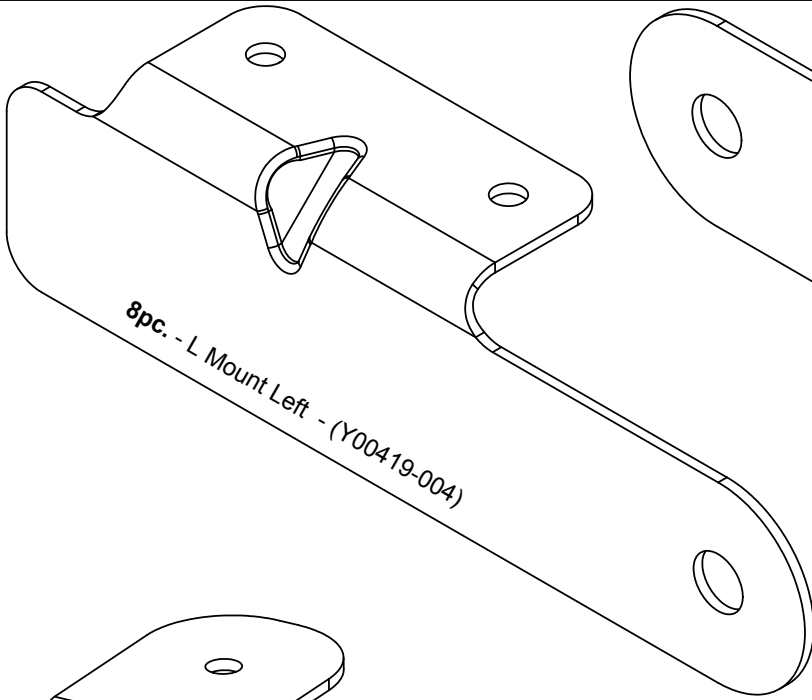

Step 1: Inventory Parts - Read This Before Starting Assembly

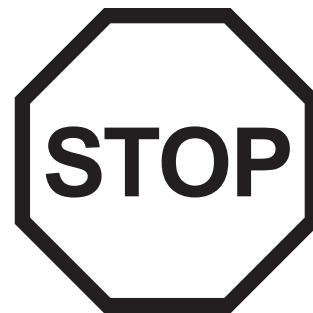
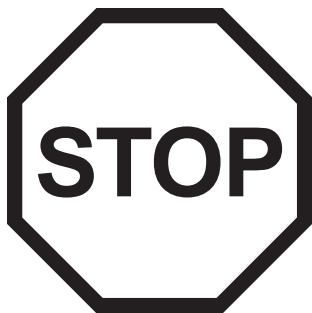

- A.** This is the time for you to inventory all your hardware, wood and accessories, referencing the parts identification sheets. This will assist you with your assembly.
- Each step indicates which bolts and/or screws you will need for assembly, as well as any flat washers, lock washers, t-nuts or lock nuts.
- B.** If there are any missing or damaged pieces or you need assistance with assembly please contact the consumer relations department directly. Call us before going back to the store.

1-888-509-4382
support@yardistrystructures.com

- C.** Read the assembly manual completely, paying special attention to ANSI warnings; notes; and safety/maintenance information on pages 1 - 4.
- Follow the instructions in order.
 - This structure is designed to be assembled and installed ideally by two people, DO NOT attempt to install alone.
 - Consider the slope of elevation where you plan to install the structure. Also, check for gas, telephone, other utilities or sprinkler line locations prior to excavating any holes.
- D.** Before you discard your cartons fill out the form below.
- The carton I.D. stamp is located on the end of each carton.
 - Please retain this information for future reference. You will need this information if you contact the Consumer Relations Department.

PRODUCT NUMBER: YM12600

CARTON I.D. STAMP: _ _ _ _ _ (Box 1)
CARTON I.D. STAMP: _ _ _ _ _ (Box 2)
CARTON I.D. STAMP: _ _ _ _ _ (Box 3)

Step 2: Assemble “X” Inserts

A: Place one X Insert Pin into one X Insert, then attach a second X Insert to form a complete Insert. Make sure the pieces are tight to each other.

B: Repeat Step A to make 32 complete Inserts.

Fig. 2.1

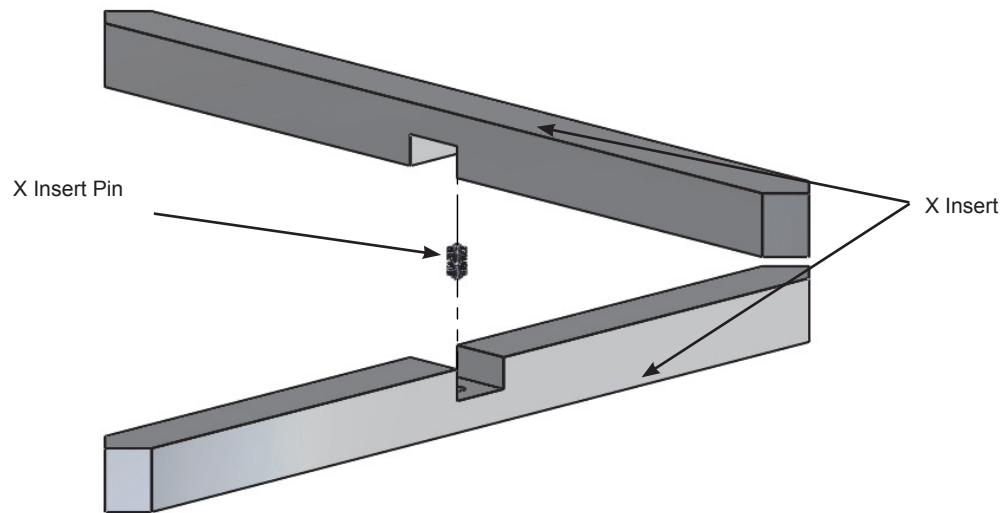

Wood Parts

64 x X Insert 38.1 x 38.1 x 574.7 mm

Hardware

32 x X Insert Pin

Step 3: Assemble 8 Panels

Part 1

Fig. 3.1

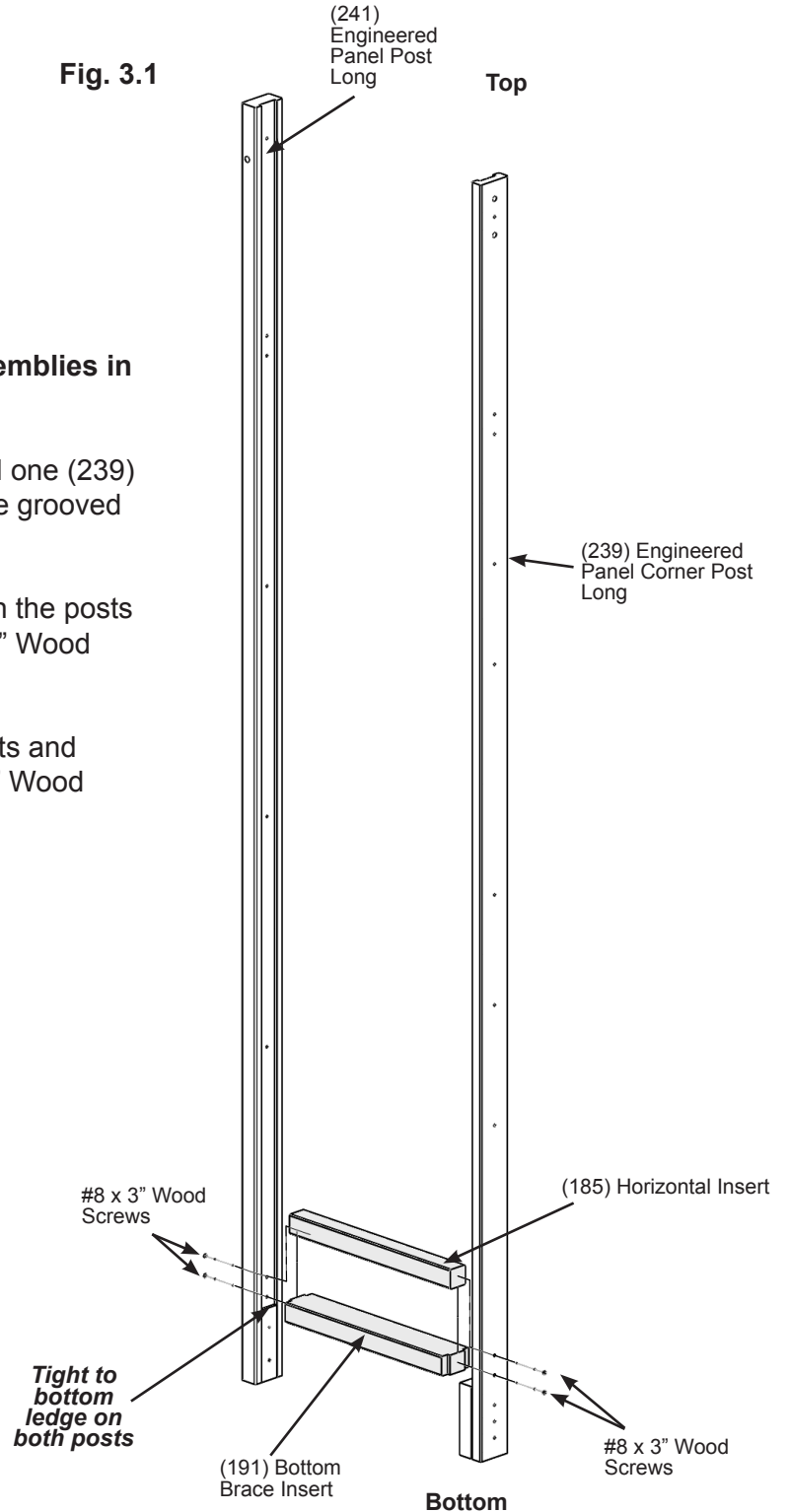

Note: You will be assembling 8 Panel Post Assemblies in total in Step 3.

A: Lay one (241) Engineered Panel Post Long and one (239) Engineered Panel Corner Post Long on edge so the grooved sides face each other, on a level surface.

B: Place one (191) Bottom Brace Insert in between the posts tight to the bottom ledge and attach with two #8 x 3" Wood Screws as shown in fig. 3.1.

C: Set one (185) Horizontal Insert between the posts and tight to Bottom Brace Insert. Attach with two #8 x 3" Wood Screw as shown in figure 3.1.

Wood Parts

- 8 x (241) Engineered Panel Post Long 36 x 69.9 x 2463.8 mm
- 8 x (191) Bottom Brace Insert 38.1 x 69.9 x 409.6 mm
- 8 x (185) Horizontal Insert 38.1 x 38.1 x 409.6 mm
- 8 x (239) Engineered Panel Corner Post Long 53.5 x 69.9 x 2463.8 mm

Hardware

- 32 x #8 x 3" Wood Screw

Step 3: Assemble 8 Panels Part 2

D: Slide one complete Insert in from the top of the panels and down to the (185) Horizontal Insert. (fig. 3.2)

E: Slide one (185) Horizontal Insert to the top of the complete Insert. (fig. 3.2) Attach with two #8 x 3" Wood Screws.

Note: Be sure to maintain 16" measurement between each (185) Horizontal Insert. (fig 3.3)

F: Repeat Steps D and E so there are four complete Inserts per Panel Post assembly. The last board should be a (189) Cross Brace Insert. Attach all three Horizontal Inserts with two #8 x 3" Wood Screws per insert and attach (189) Cross Brace Insert with four #8 x 3" Wood Screws. (fig. 3.3)

Fig. 3.2

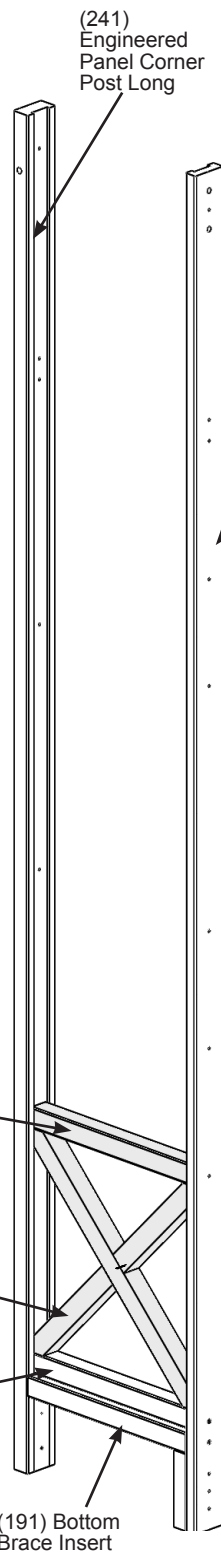
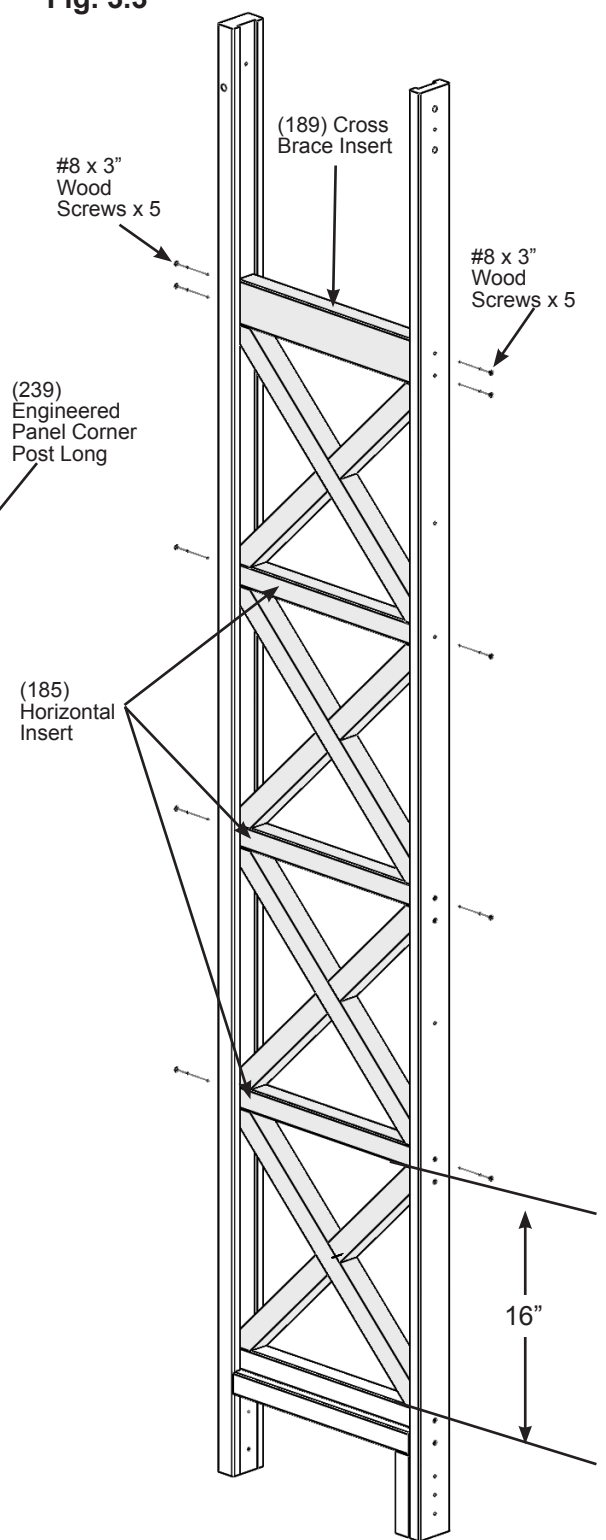

Fig. 3.3



Wood Parts

32 x Completed Inserts from Step 2
 8 x (189) Cross Brace Insert 38.1 x 76.2 x 409.6 mm
 24 x (185) Horizontal Insert 38.1 x 38.1 x 409.6 mm

Hardware

80 x #8 x 3" Wood Screw

Step 4: Attach Panel Posts to Corner Posts Part 1



Fig. 4.1

(241)
Engineered
Panel Post
Long

(239)
Engineered
Panel Corner
Post Long

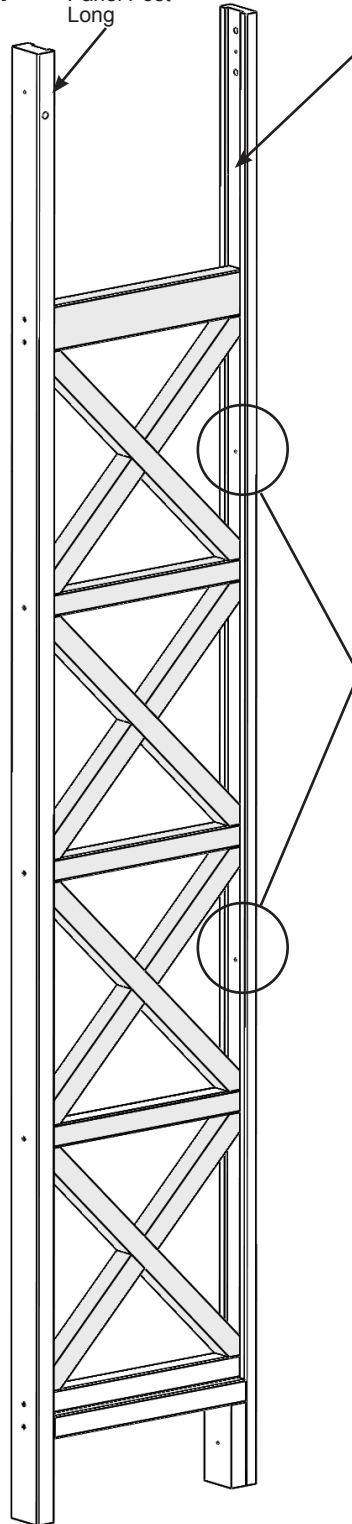

Note: Only pre-drill one post per assembly

A: On (239) Engineered Panel Corner Post Long, per assembly, pre-drill two holes from the inside, at the places shown in fig. 4.1 and 4.2. Pre-drill in the centre of the panel and on a slight angle.

Fig. 4.2

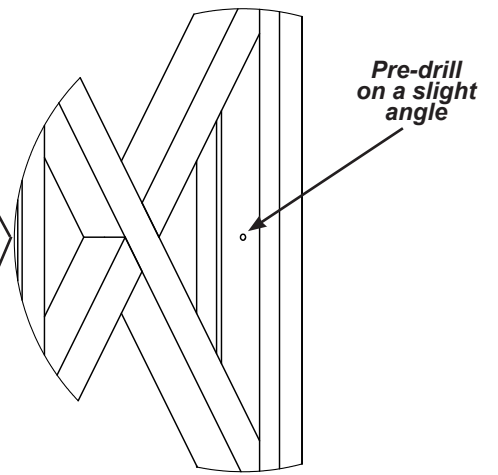

Step 4: Attach Panel Posts to Corner Posts Part 2

Fig. 4.3

B: Through the pre-drilled holes attach two Panel Posts assemblies to one (235) Corner Post Long with one #10 x 4" Wood Screw per Panel Post Assembly at bottom and six #8 x 2-1/2" Wood Screws along post as shown in fig. 4.3.

Complete this step for all four Corner Posts.

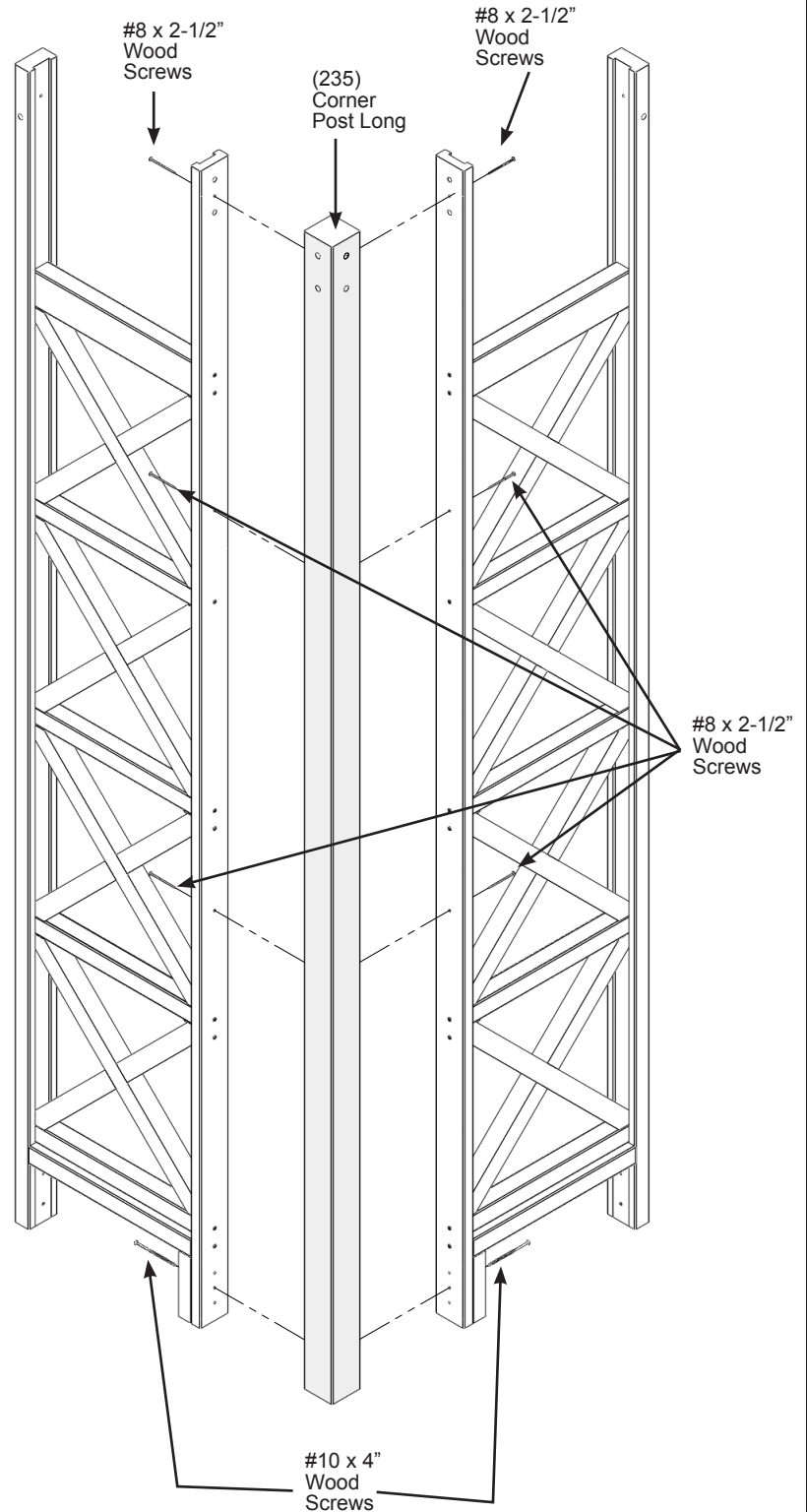
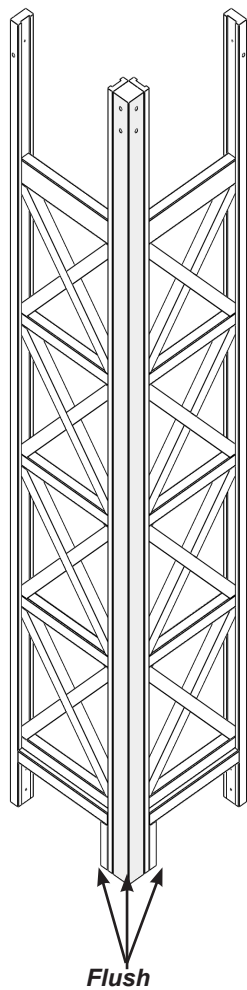

Wood Parts

4 x (235) Corner Post Long 69.9 x 69.9 x 2463.8 mm

Hardware

8 x #10 x 4" Wood Screw

24 x #8 x 2-1/2" Wood Screw

Step 5: Attach L - Mount Brackets



A: Pre-drill with a 1/8" drill bit and attach two L Mounts (one L Mount Right and one L Mount Left) flush to the inside edge, at the bottom of each Panel Post with two #10 x 1-1/4" Pan Screw per L Mount as shown in fig. 5.1, 5.2 and 5.3.

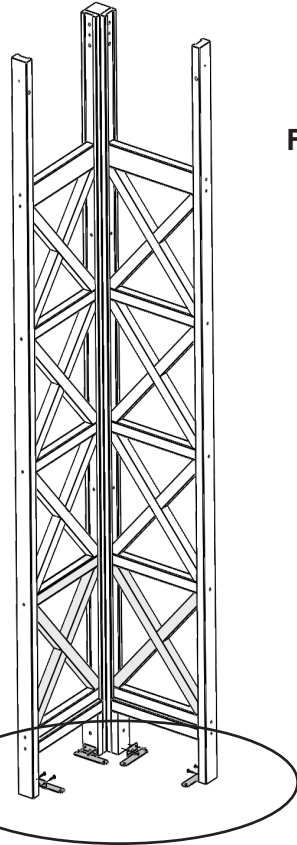

Fig. 5.1

Note orientation of tabs.

#10 x 1-1/4" Pan Screw x 2 per L Mount

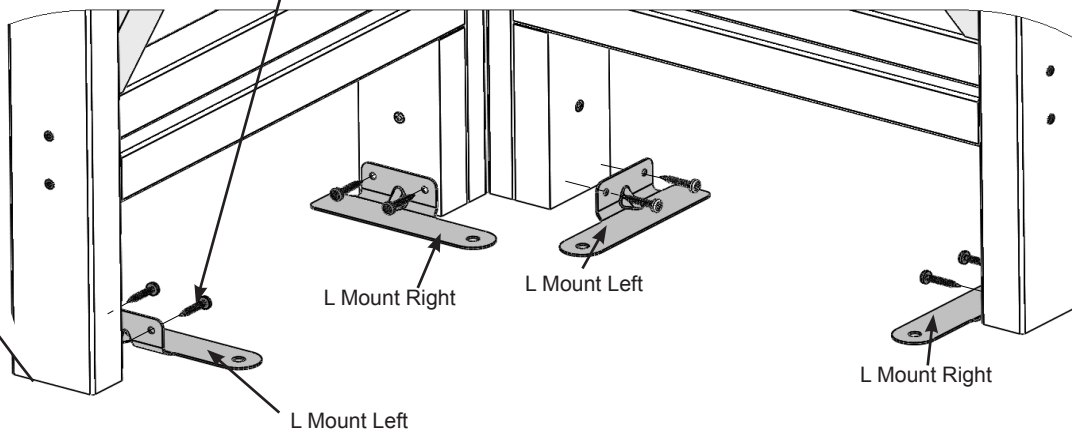
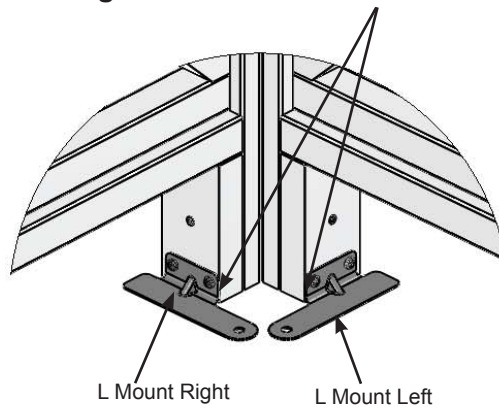

Fig. 5.2

Fig. 5.3

Note: Flush to the inside edge.



Hardware

16 x Room L-Mount (Right and Left)

32 x #10 x 1-1/4" Pan Screw

Step 6: Attach Plinths to Corner Post Assembly

Part 1

A: Place one (034) Short Plinth B Assembly with one (035) Short Plinth A Assembly tight to each other and attach using two #6 x 30 mm Trim Screw at the opposite corners per Plinth. (Fig. 6.1 and 6.2)

Note: Plinths will be attached to four corners.

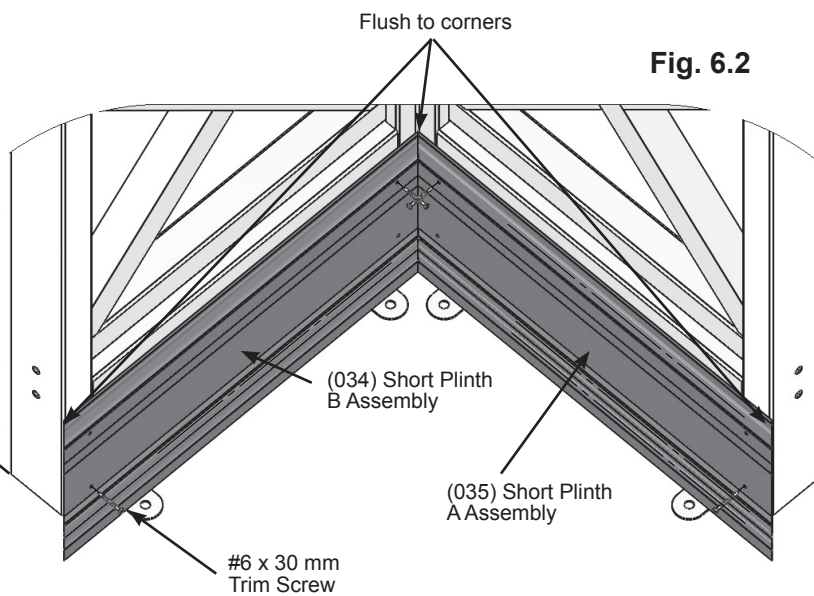
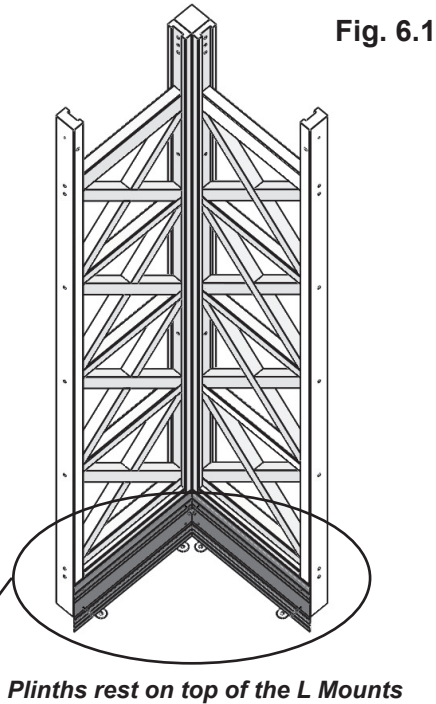

Wood Parts

4 x (035) Short Plinth A Assembly 34.9 x 152.4 x 492.1 mm
4 x (034) Short Plinth B Assembly 34.9 x 152.4 x 492.1 mm

Hardware

16 x #6 x 30 mm Trim Screw

Step 6: Attach Plinths to Corner Post Assembly

Part 2

B: On the outside of the corner post assembly, place two (033) Long Plinth Assembly tight against each other using 2 #6 x 30 mm Trim Screws per Plinth. Be sure they are flush and tight. (Fig. 6.3 and 6.4)

Fig. 6.4

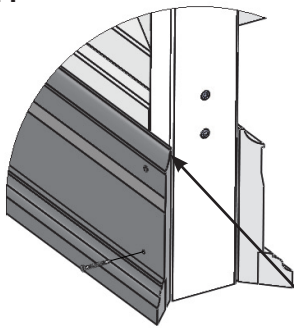
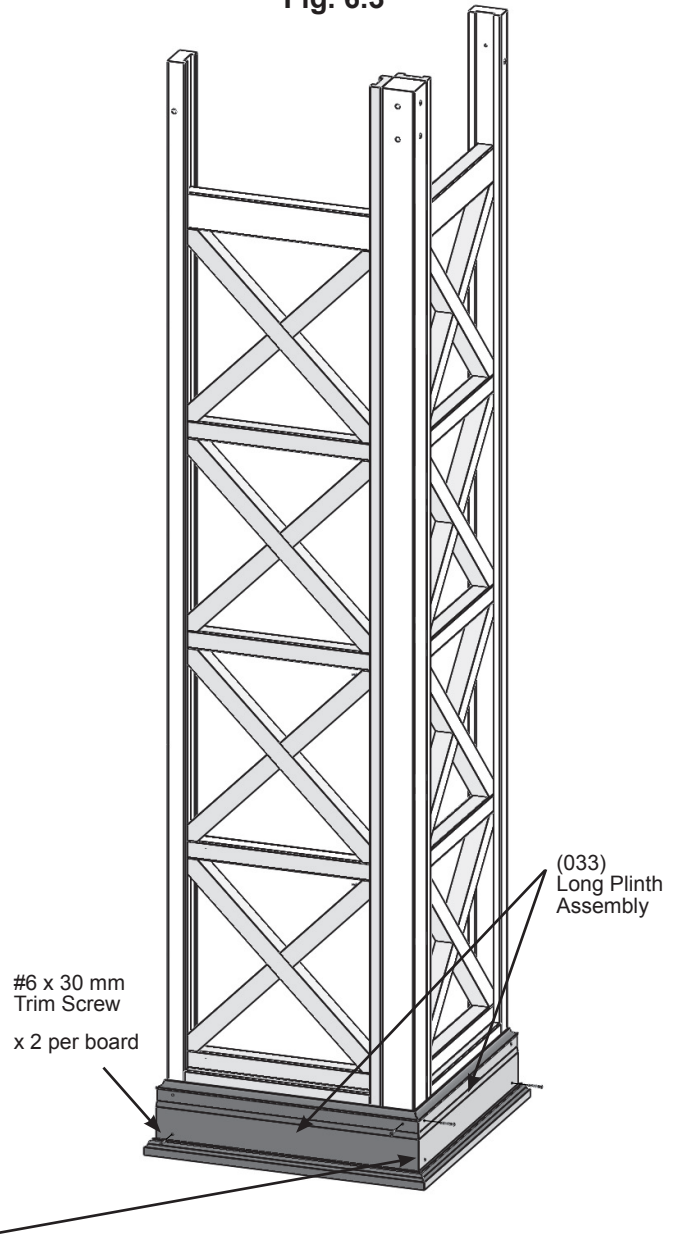

Fig. 6.3



#6 x 30 mm
Trim Screw
x 2 per board

(033)
Long Plinth
Assembly

Flush

Wood Parts

8 x (033) Long Plinth Assembly 34.9 x 152.4 x 598.5 mm

Hardware

16 x #6 x 30 mm Trim Screw

Step 6: Attach Plinths to Corner Post Assembly

Part 3

C: Place one (032) End Plinth Assembly onto each Corner Post Assembly. Line them up with previously placed Plinths. Make sure they are flush and tight to each other and then fasten with two #6 x 30 mm Trim Screw per end. (Fig. 6.5 and 6.6)

Fig. 6.5

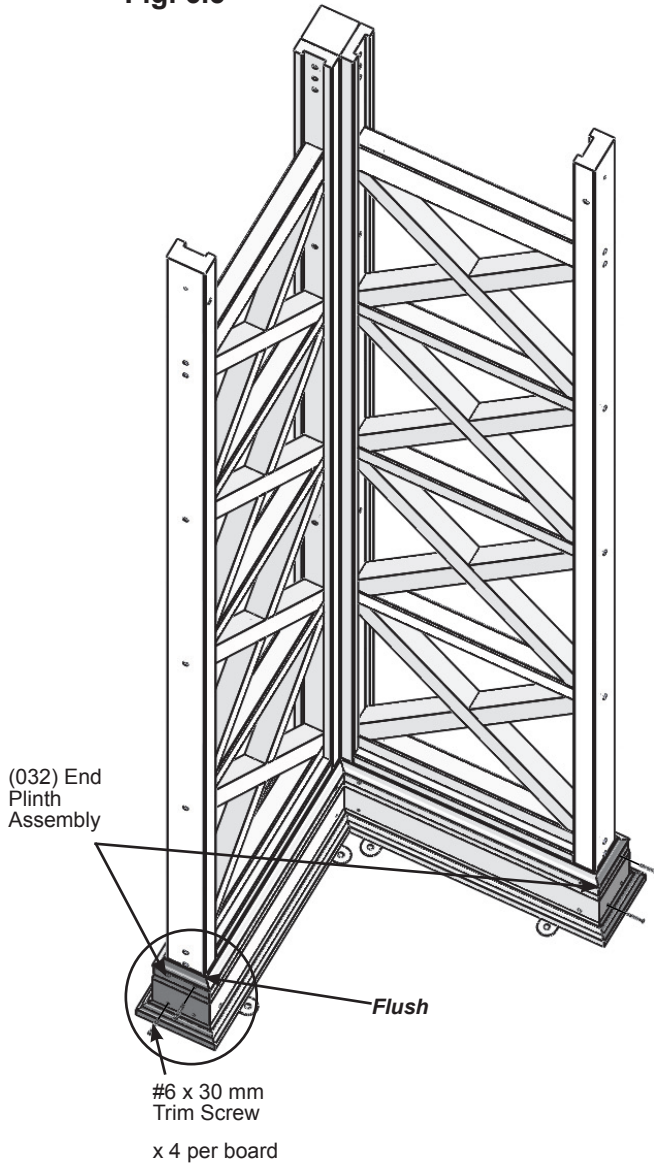
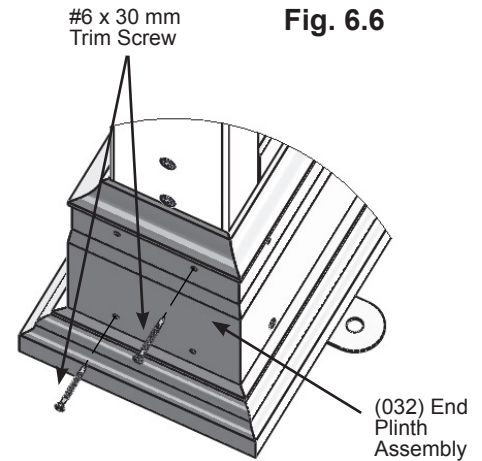

Fig. 6.6



Note: Loosen screws as necessary to align all edges.

Wood Parts

8 x (032) End Plinth Assembly 34.9 x 152.4 x 141.3 mm

Hardware

16 x #6 x 30 mm Trim Screw

Step 6: Attach Plinths to Corner Post Assembly

Part 4

Note: Make sure all plinths are lined up, flush and level before installing remaining screws.

D: After the End Plinth have been placed, go back and install the two remaining #6 x 30 mm Trim Screws per end to the assembled Plinth of the Pergola Room. (Fig. 6.7 and 6.8)

E: Attach 2 #6 x 30 mm Trim Screws to each end side as shown in fig. 6.7 and 6.8.

Fig. 6.7

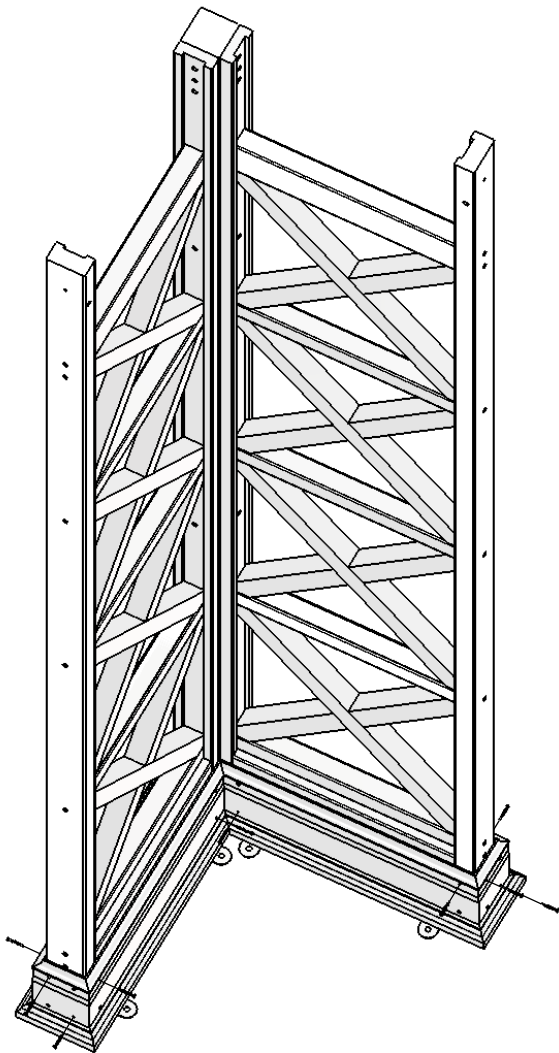
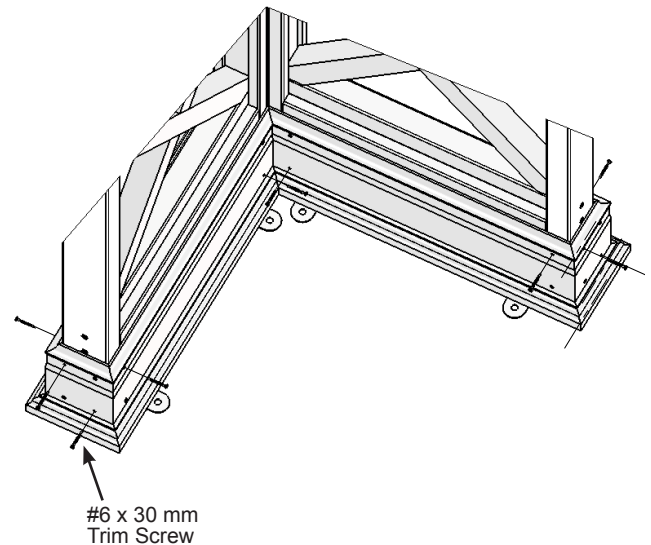

Fig. 6.8



Hardware

48 x #6 x 30 mm Trim Screw

Step 7: Locate Corner Post Assemblies



A: Move your Corner Post Assemblies to the final location. Make sure the ground is flat and level before continuing assembly.

B: Stand all four complete Corner Post Assemblies so they form a rectangle as shown in fig. 7.1. See figure 7.1 and 7.2 for accurate placements and additional measurements.

Fig. 7.1

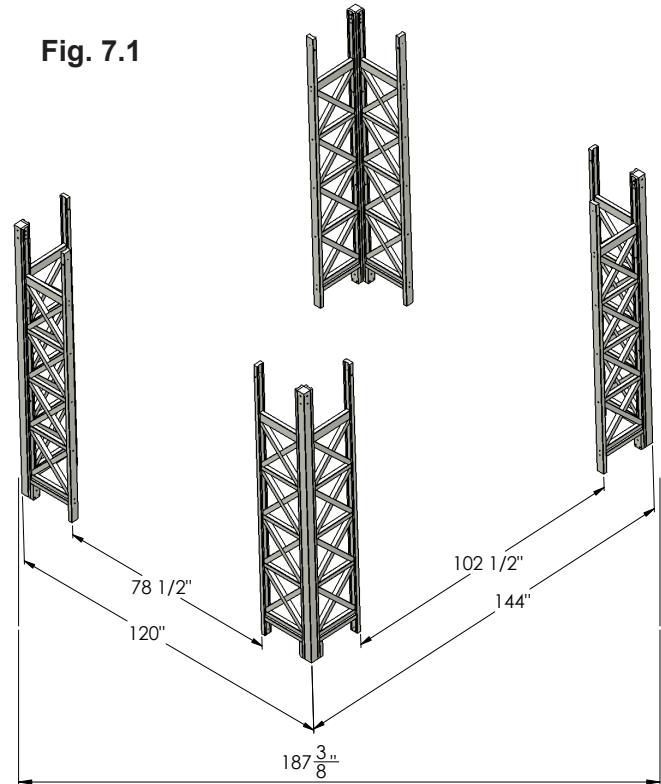
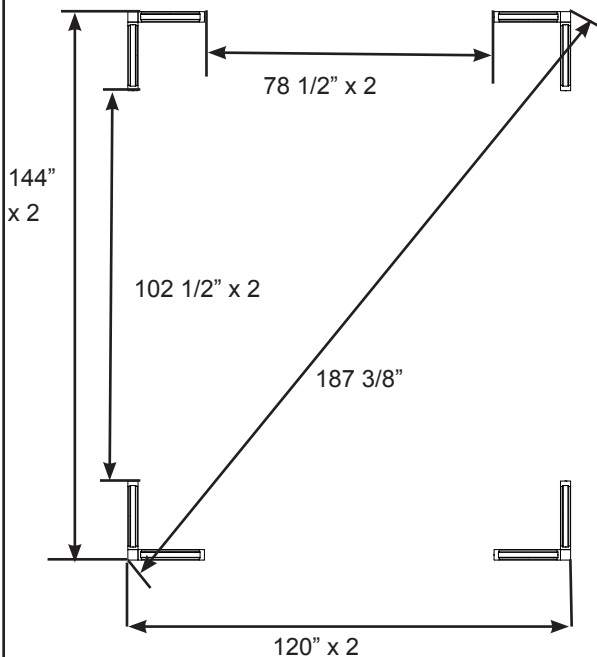

Fig. 7.2



C: Depending on what you are placing the Pergola Room on will determine how you anchor it to that surface. Please refer to pages 4 and 5 for installation examples.

Any hardware or extra materials for mounting will have to be purchased in advance.

Step 8: Assemble Beam Ends



A: On a flat and level surface attach one (069) Beam End 10-1/2" to (192) Beam End 34-1/4" with three #10 x 4" Wood Screws as shown in fig. 8.1.

B: Repeat Step A three more times so you have four assemblies. Note that two of the Beam Ends should be on the same side as the cut out and two should be on the opposite side. (fig. 8.1 and 8.2)

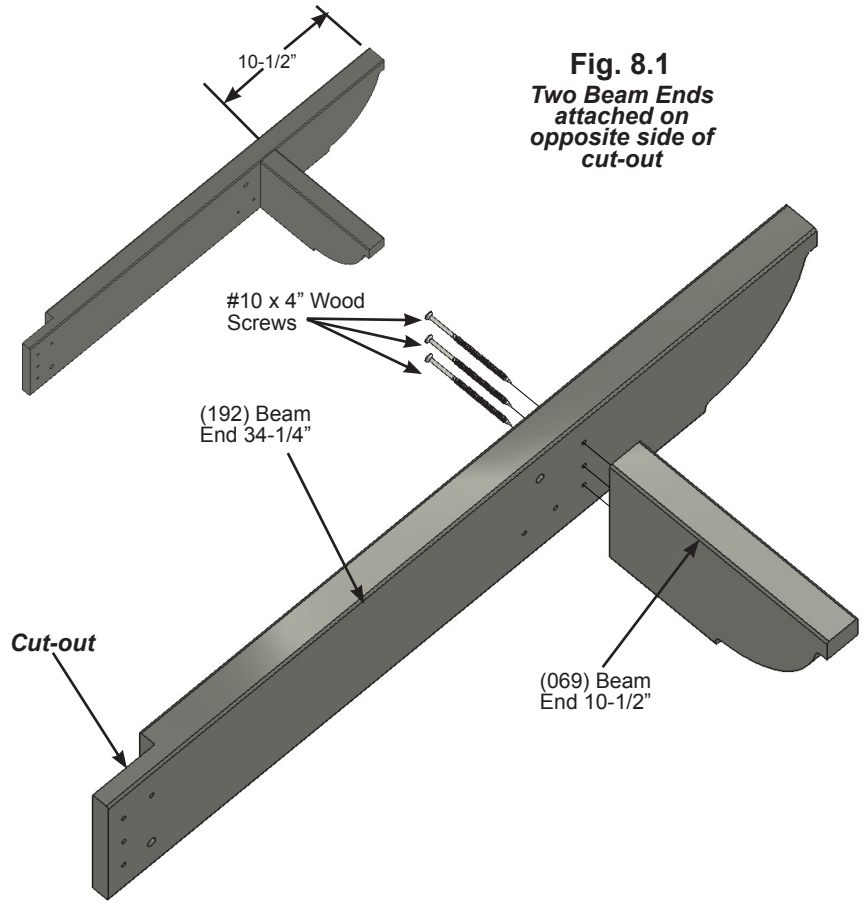

Fig. 8.1
Two Beam Ends attached on opposite side of cut-out

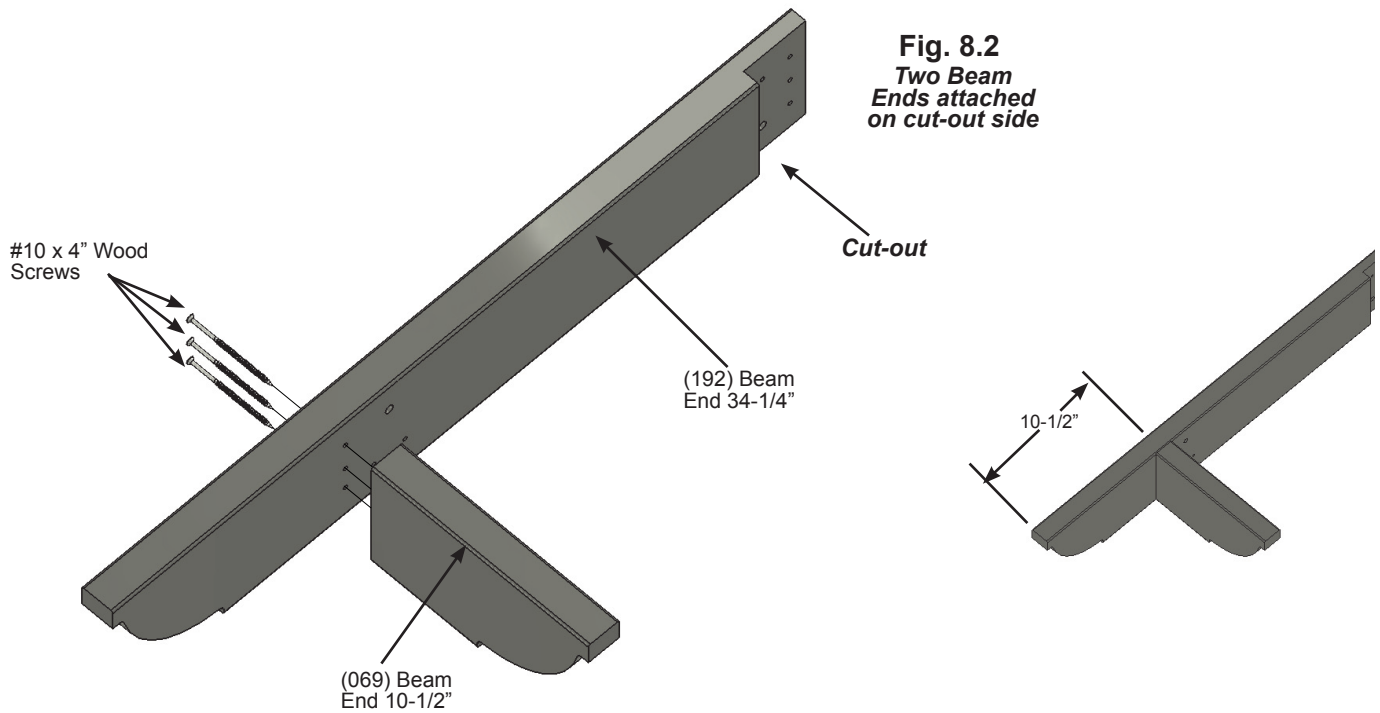

Fig. 8.2
Two Beam Ends attached on cut-out side

Wood Parts

- 4 x (192) Beam End 34-1/4" 38.1 x 139.7 x 870 mm (2 x 6 x 34-1/4")
- 4 x (069) Beam End 10-1/2" 38.1 x 139.7 x 266.7 mm (2 x 6 x 10-1/2")

Hardware

- 12 x #10 x 4" Wood Screw

Step 9: Attach Beams to Corner Post Assemblies



It is important the proper hardware gets placed in the places shown. You install the Hex Bolts first and then the screws.

A: Loosely attach one Beam End assembly from Step 8 to each Corner Post assembly with the cut-out side facing out using one 5/16 x 5" Hex Bolt (with 5/16" flat washer, 5/16" lock washer and 5/16" T nut)

Note: Beams should be flush to top of posts.

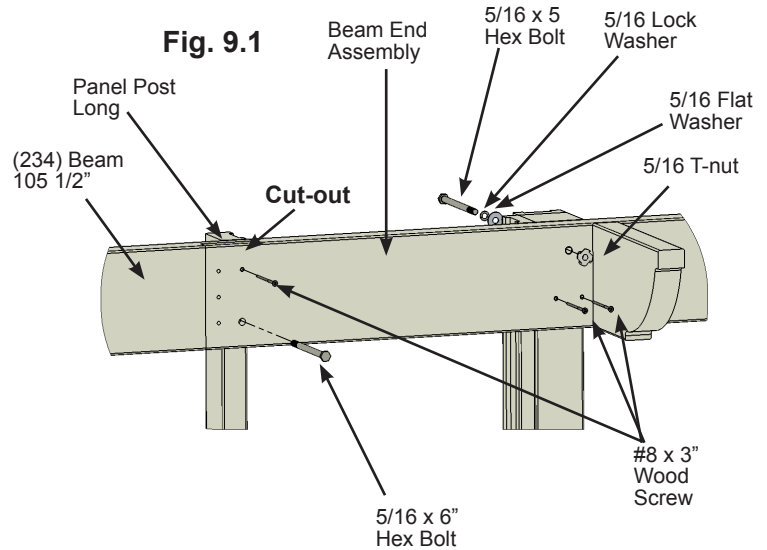
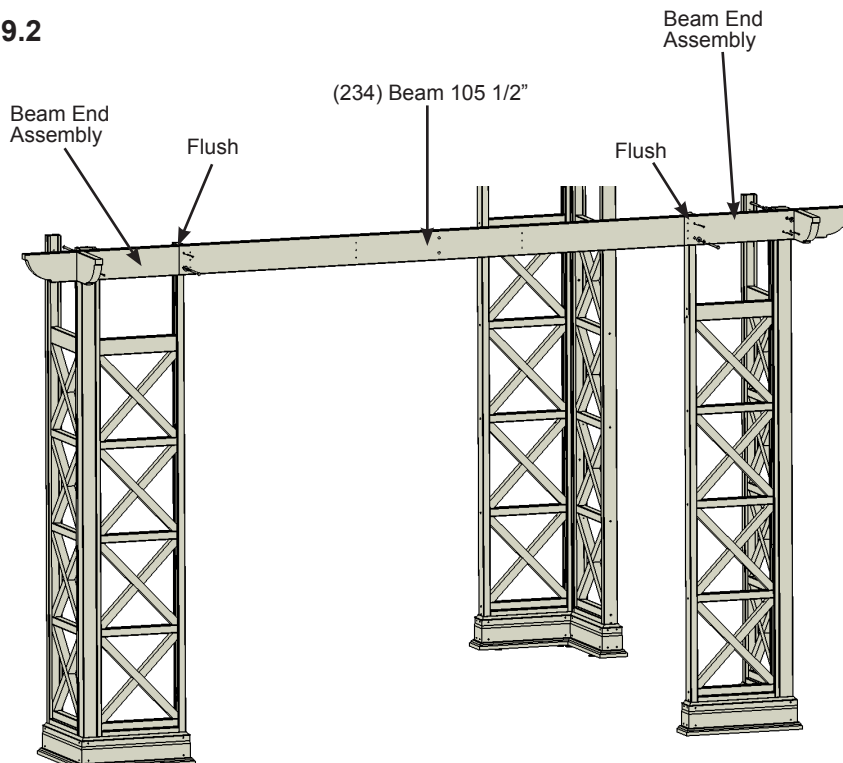

Fig. 9.2



B: Fit one (234) Beam 105-1/2" in between two Corner Post Assemblies and attach to Beam End assemblies and Panel Post as shown in fig. 9.1 and 9.2 with one 5/16 x 6" Hex Bolt. **This bolt is only used for hole alignment at this point.**

C: Attach six #8 x 3" Wood Screws.

D: Repeat Steps A, B and C to the opposite pair of Panel Corner Post Assemblies to make a front and back.

Wood Parts

2 x (234) Beam 105-1/2" 38.1 x 139.7 x 2679.7 mm

Hardware

12 x #8 x 3" Wood Screw

4 x 5/16 x 6" Hex Bolt (5/16" flat washer, 5/16" lock washer, 5/16" t-nut)

4 x 5/16 x 5" Hex Bolt (5/16" flat washer, 5/16" lock washer, 5/16" t-nut)

Step 10: Attach Arch Beam Fronts



It is important the proper hardware gets placed in the places shown. Make sure you install the Hex Bolts first and then the Fig. 10.1 wood screws.

A: Attach one (195) Arch Beam Front in between two Corner Post Assemblies as shown in fig. 10.2 and attach to Corner Post Assembly with one 5/16 x 5" Hex Bolt (with 5/16" flat washer, 5/16" lock washer and 5/16 t-nut); and one 5/16 x 4 1/2" Hex Bolt (with 5/16" flat washer, 5/16" lock washer and 5/16" t-nut) per side. (fig. 10.1)

B: Attach three #8 x 3" wood screws per side.

C: Repeat for the opposite side.

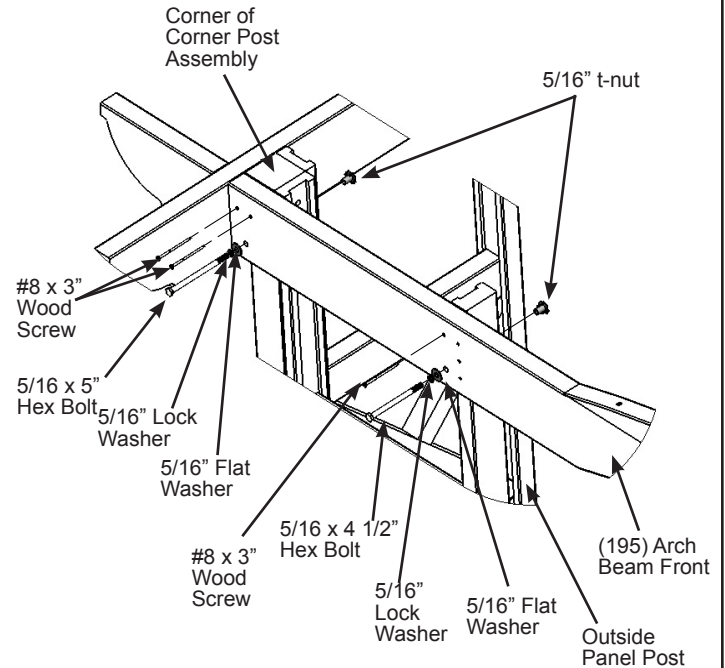
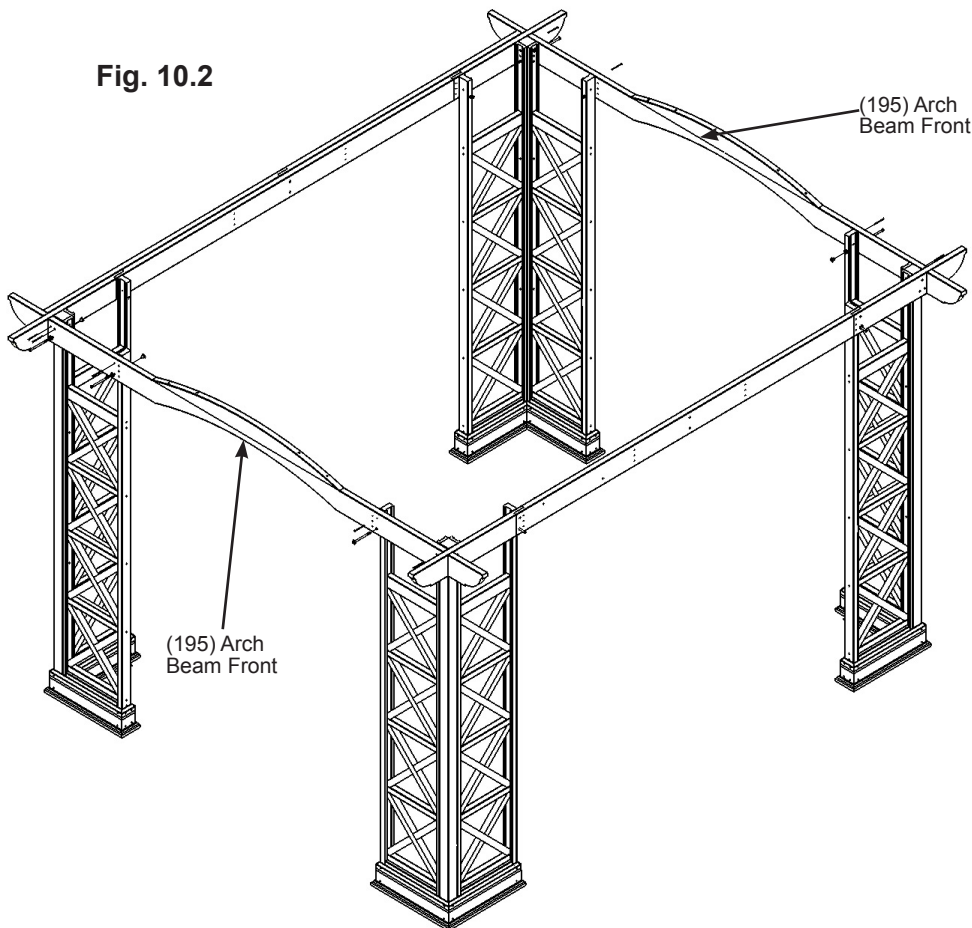

Fig. 10.2



Wood Parts

2 x (195) Arch Beam Front 38.1 x 241.3 x 3048 mm (2 x 6 x 120")

Hardware

12 x #8 x 3" Wood Screw

4 x 5/16 x 4-1/2" Hex Bolt (5/16" flat washer, 5/16" lock washer, 5/16" t-nut)

4 x 5/16 x 5" Hex Bolt (5/16" flat washer, 5/16" lock washer, 5/16" t-nut)

Step 11: Attach Arch Beam Offsets



It is important the proper hardware gets placed in the places shown.

A: Attach one (080) Arch Beam Offset through centre of grooves of Engineered Panel Post with one #8 x 2-1/2" Wood Screw and through Beam 81-1/2" with three #10 x 4" Wood Screws per side shown in fig. 11.1 and 11.2. Complete for two Arch Beam Offsets.

B: In between Arch Beam Fronts and Arch Beam Offsets, next to the Engineered Panel Posts install four (067) Beam 20-3/4" and attach with one #8 x 2-1/2" Wood Screw and six #10 x 4" Wood Screws per Beam 20-3/4" as shown in fig. 11.1 and 11.2.

Fig. 11.1

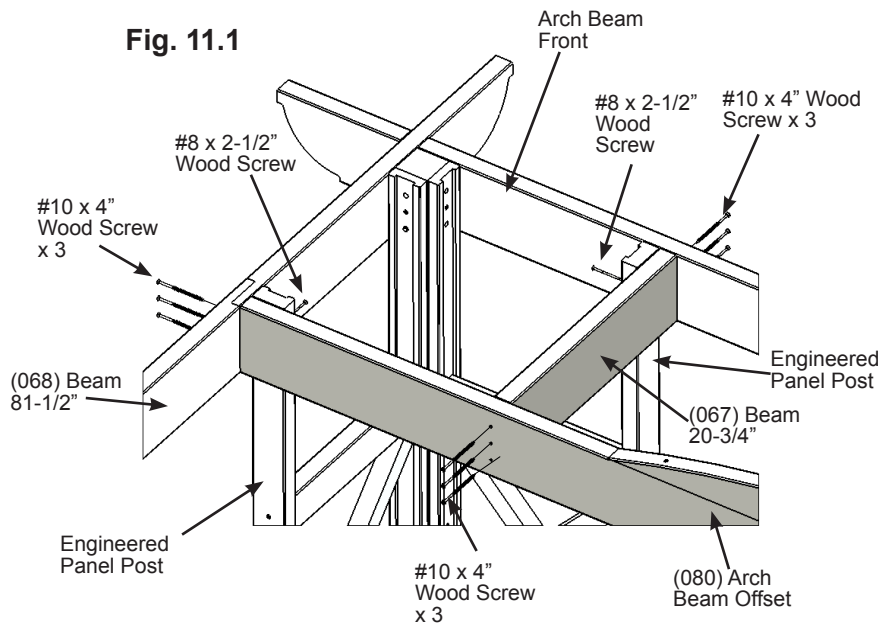
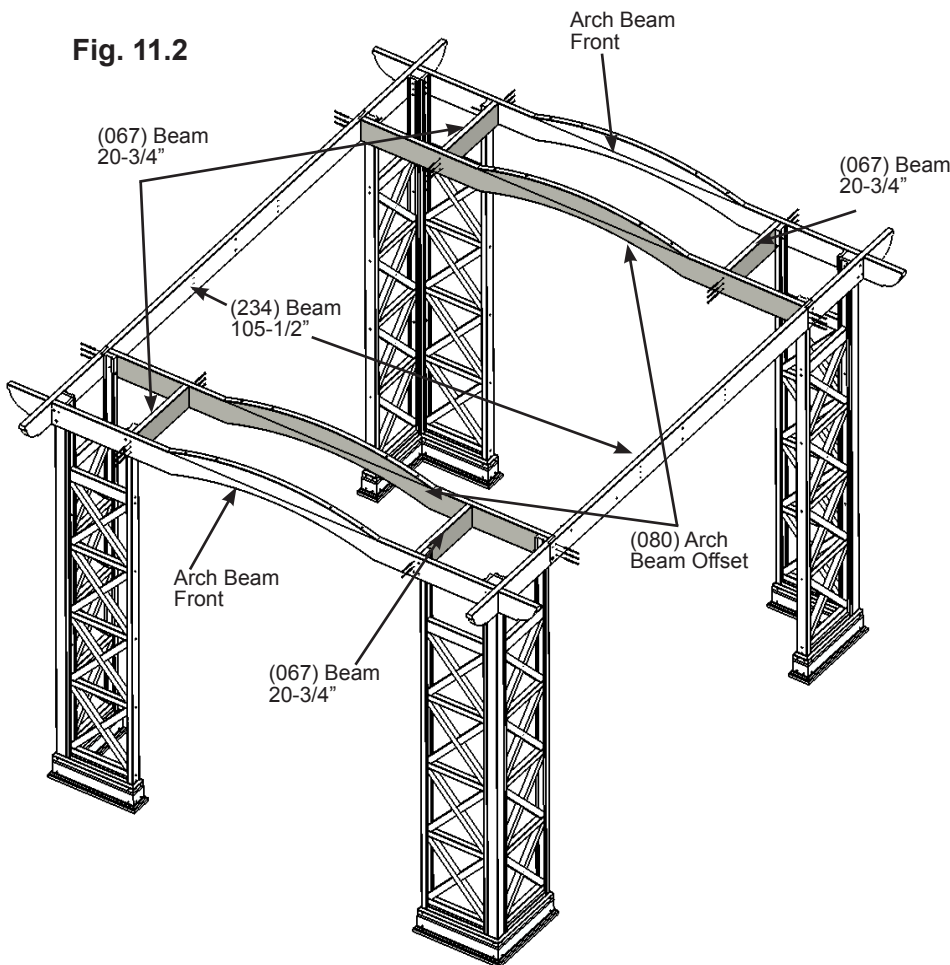

Fig. 11.2



Wood Parts

- 2 x (080) Arch Beam Offset 38.1 x 241.3 x 3048 mm
- 4 x (067) Beam 20-3/4" 38.1 x 139.7 x 527.1 mm

Hardware

- 36 x #10 x 4" Wood Screw
- 8 x #8 x 2-1/2" Wood Screw

Step 12: Attach Arch Beam Centres Part 1



A: Centre (079) Arch Beam Centres over the pilot holes in (234) Beam 105-1/2" and attach using six #10 x 4" Wood Screws per side (fig. 12.3 & 12.4)

B: Repeat Step C for second (079) Arch Beam Centre. (fig. 12.4)

Fig. 12.3

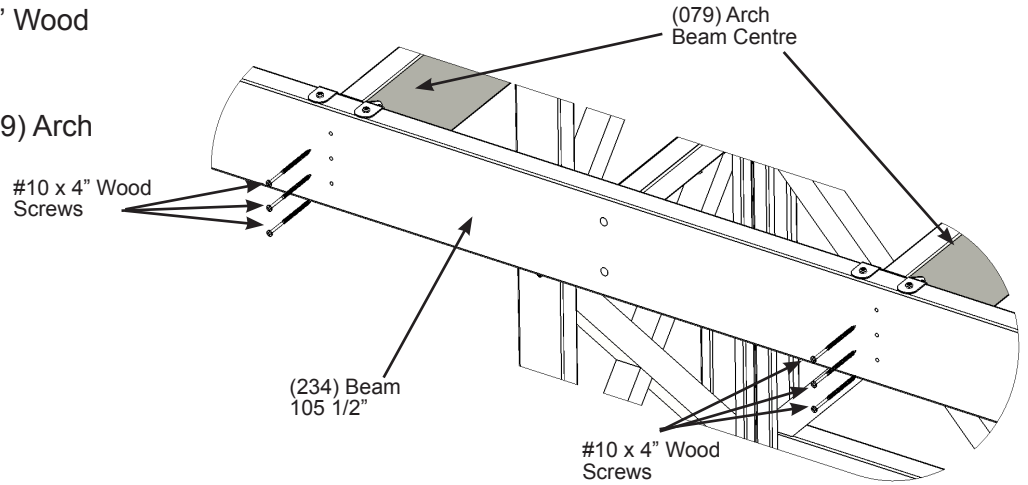
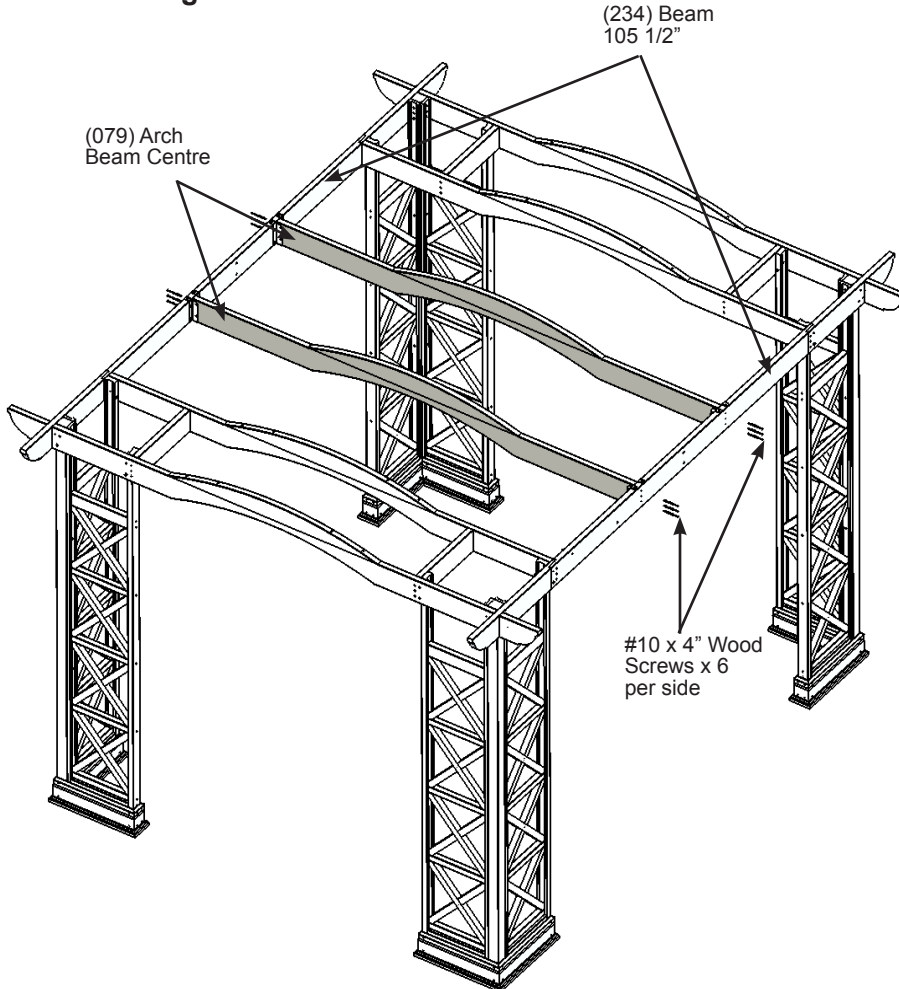

Fig. 12.4



Hardware

12 x #10 x 4" Wood Screw

Step 12: Attach Arch Beam Centres Part 2



C: Attach one (079) Arch Beam Centre to each (234) Beam 105-1/2" using one Beam Hanger and eleven #10 x 1 1/4" Pan Screw (fig. 12.1 & 12.2)

D: Repeat Step A for second (079) Arch Beam Centre. (fig 12.2)

Fig. 12.1

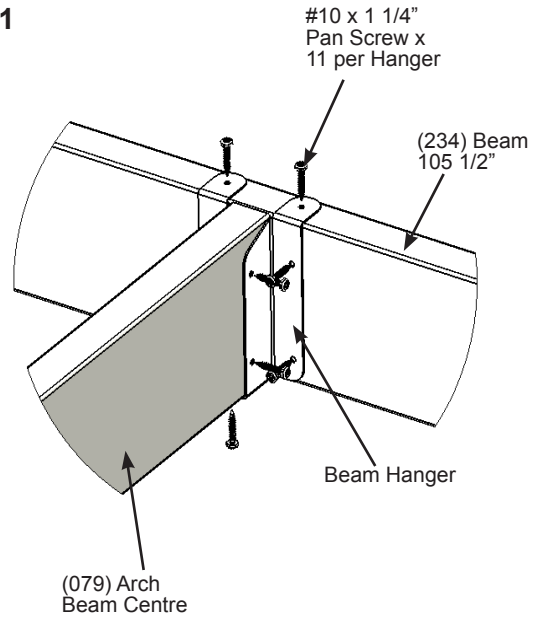
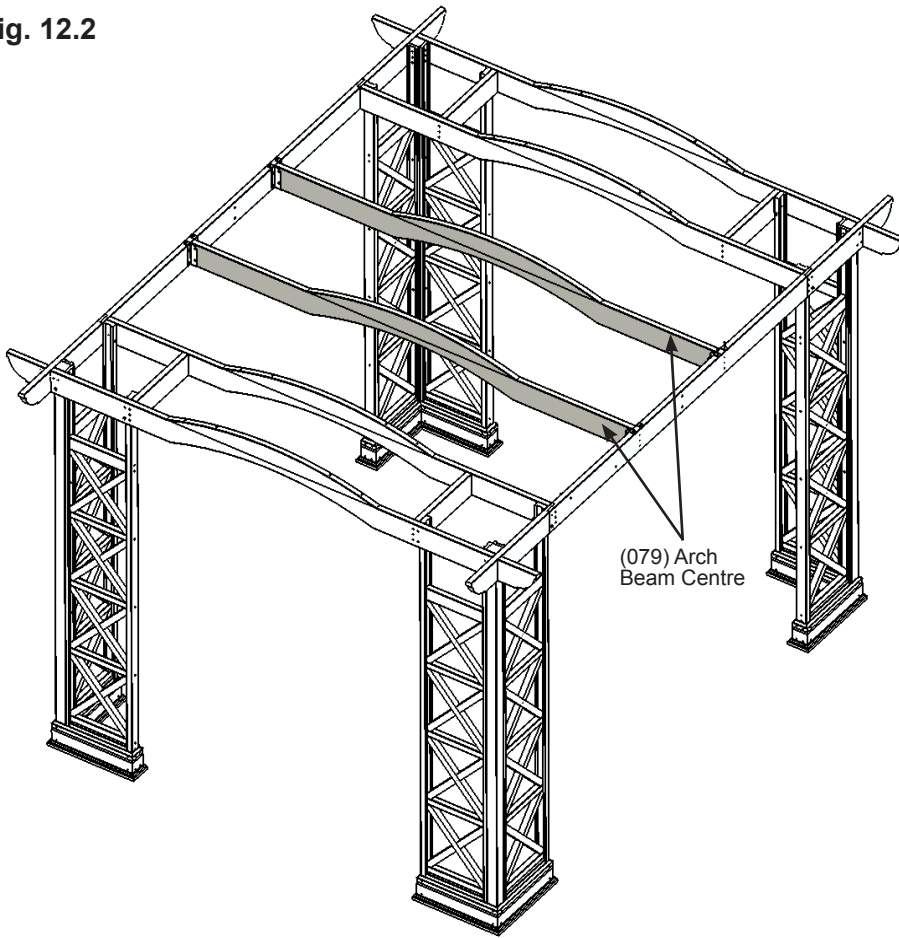

Fig. 12.2



Wood Parts

2 x (079) Arch Beam Centre 38.1 x 241.3 x 3048 mm

Hardware

44 x #10 x 1 1/4" Pan Screw
4 x Arch Beam Hanger

Step 13: Attach Support Beams Part 1



A: Leaving the T-nut installed, remove the 5/16 x 6" Hex Bolt (5/16" lock washer and 5/16" flat washer) from each Beam End Assembly installed in Step 9. (fig. 13.1 & 13.2)

Fig. 13.1

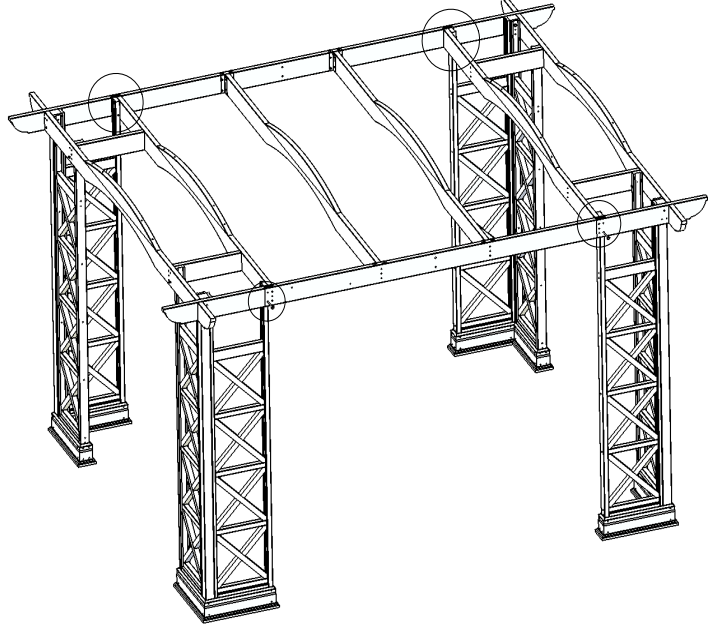
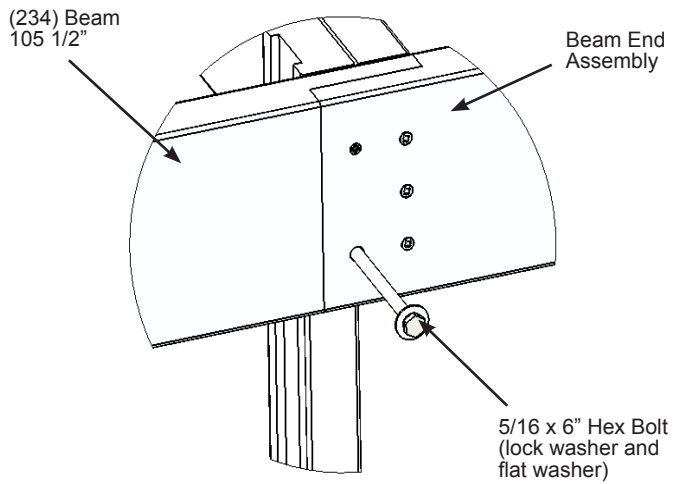

Fig. 13.2



Hardware

Step 13: Attach Support Beams Part 2



It is important the proper hardware gets placed in the places shown.

B: Attach one (231) Support Beam to each Beam End Assembly and (235) Engineered Panel Corner Post Long by replacing the 5/16 x 6" Hex Bolt (lock washer and flat washer) removed in Part 1. (fig 13.3 & 13.4) Ensure the cut outs in the boards are interlocking as shown in fig. 13.5.

C: Using two 5/16 x 3" Hex Bolts (with lock washer, flat washer and t-nut) attach the interlocking cut outs of (231) Support Beams to (234) Beam 105 1/2" as shown in fig. 13.5.

Fig. 13.3

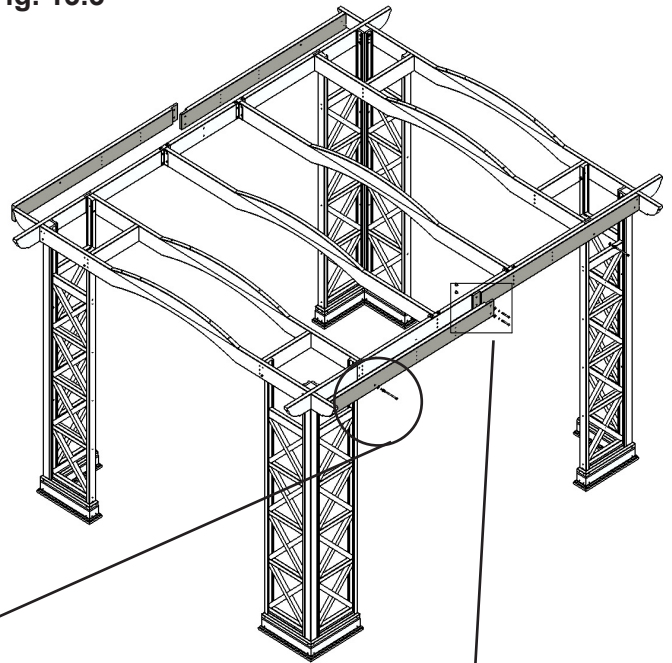

Fig. 13.4

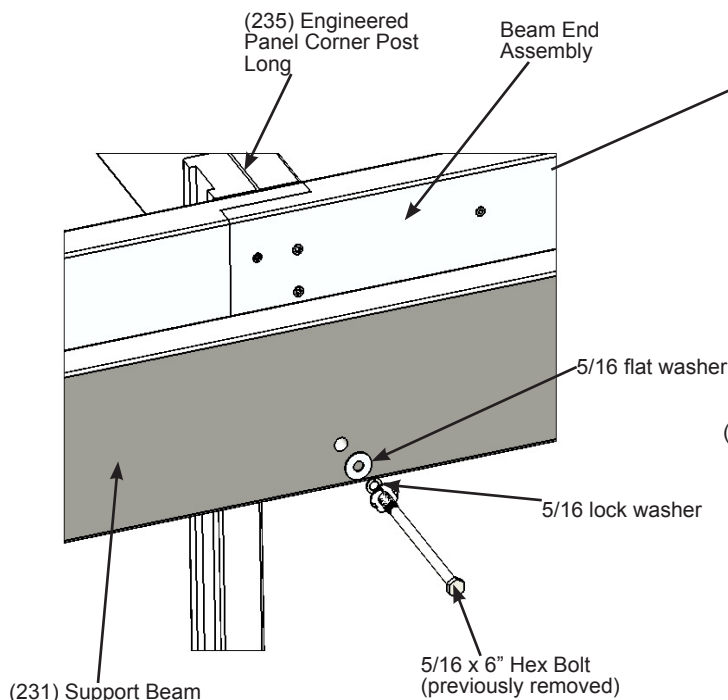
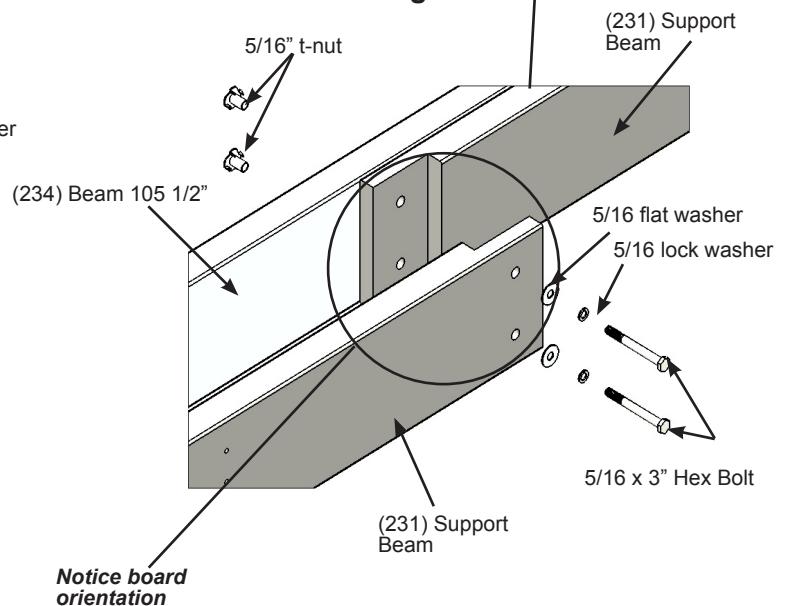

Fig. 13.5



Wood Parts

4 x (231) Support Beam 38.1 x 139.7 x 1866.9 mm

Hardware

4 x 5/16 x 3" Hex Bolt
 (5/16 flat washer, 5/16 lock washer, 5/16" T-nut)
 4 x 5/16 x 6" Hex Bolt (previously removed)
 (5/16 flat washer, 5/16" lock washer & previously installed 5/16" T-nut)

Step 13: Attach Support Beams Part 3



Fig. 13.6

D: Attach (231) Support Beams to (234) Beam 105 1/2" using sixteen #8 x 2 1/2" Wood Screws per side as shown in fig.13.6 & 13.7.

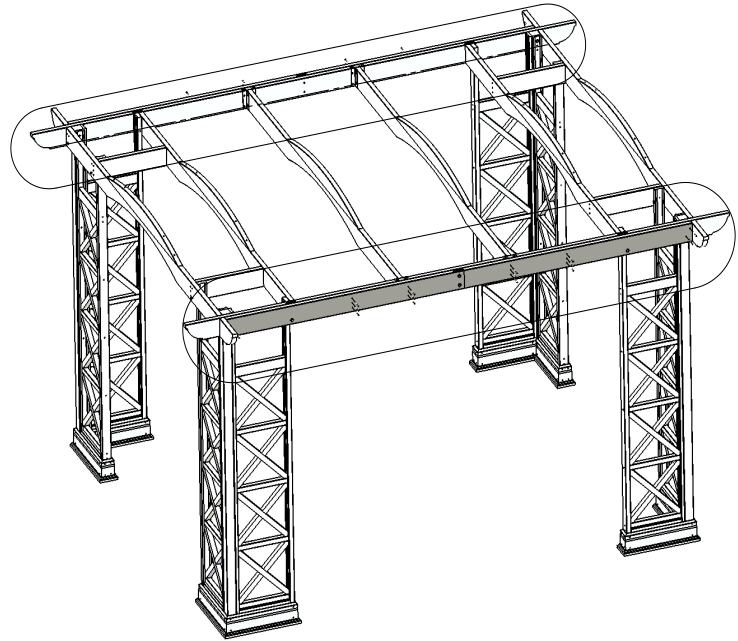
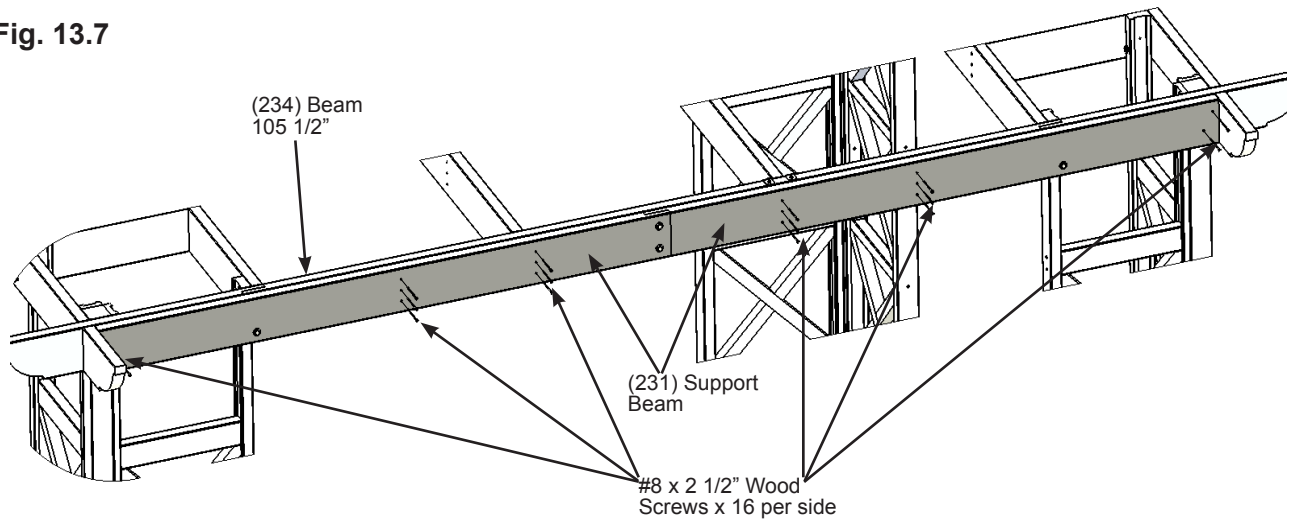

Fig. 13.7



Hardware

32 x #8 x 2 1/2" Wood Screws

Step 14: Assemble Trellis Ends

A: On a flat and level surface, fit together one (233) Trellis End Short and one (232) Trellis End Long. (fig. 14.1)

B: Place one Trellis Clip over the joined ends and attach with one 1/4 x 2" Hex Bolt (with two 1/4" flat washer and 1/4" lock nut). (fig. 14.2)

C: Repeat Steps A and B until there are 9 Trellis End Assemblies.

Fig. 14.1

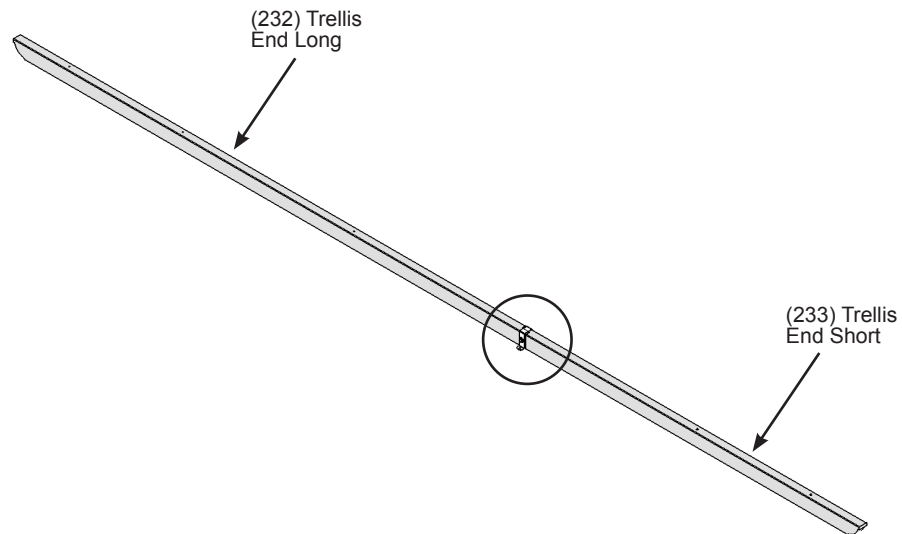
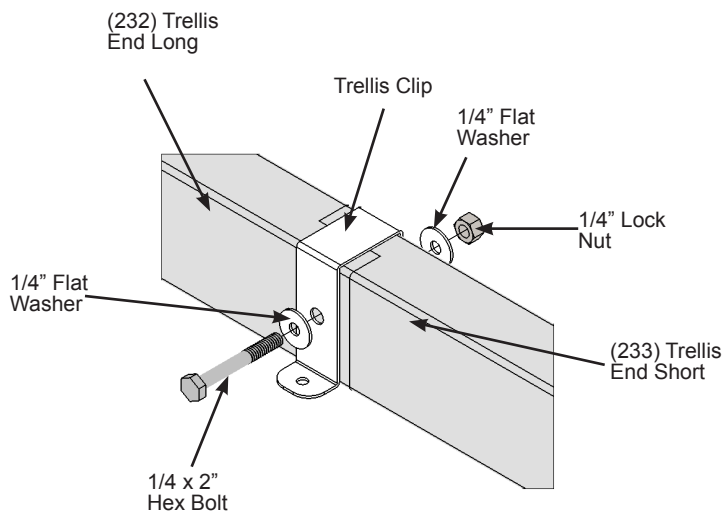

Fig. 14.2



Wood Parts

9 x (232) Trellis End Long 38.1 x 63.5 x 2554.8 mm
9 x (233) Trellis End Short 38.1 x 63.5 x 1699.7 mm

Hardware

9 x Trellis Clip
9 x 1/4 x 2" Hex Bolt (1/4" flat washer x 2, 1/4" lock nut)

Step 15: Attach Trellis End Assemblies Part 1

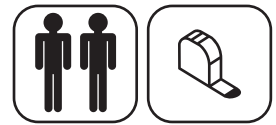

A: Measure 59-1/4" from the inside of each (234) Beam 105-1/2" and place one Trellis End Assembly on the (080) Arch Beam Offsets, (079) Arch Beam Centres and (195) Arch Beam Fronts. This should be centred and both ends should hang 9-3/4" over the edges. (fig. 15.1 and 15.4)

B: Attach with five #10 x 4" Wood Screws in the places indicated in fig. 15.1 and 15.2.

C: Attach Trellis Clip to (080) Arch Beam Centre with two #10 x 1-1/4" Pan Screws as shown in fig. 15.1 and 15.3.

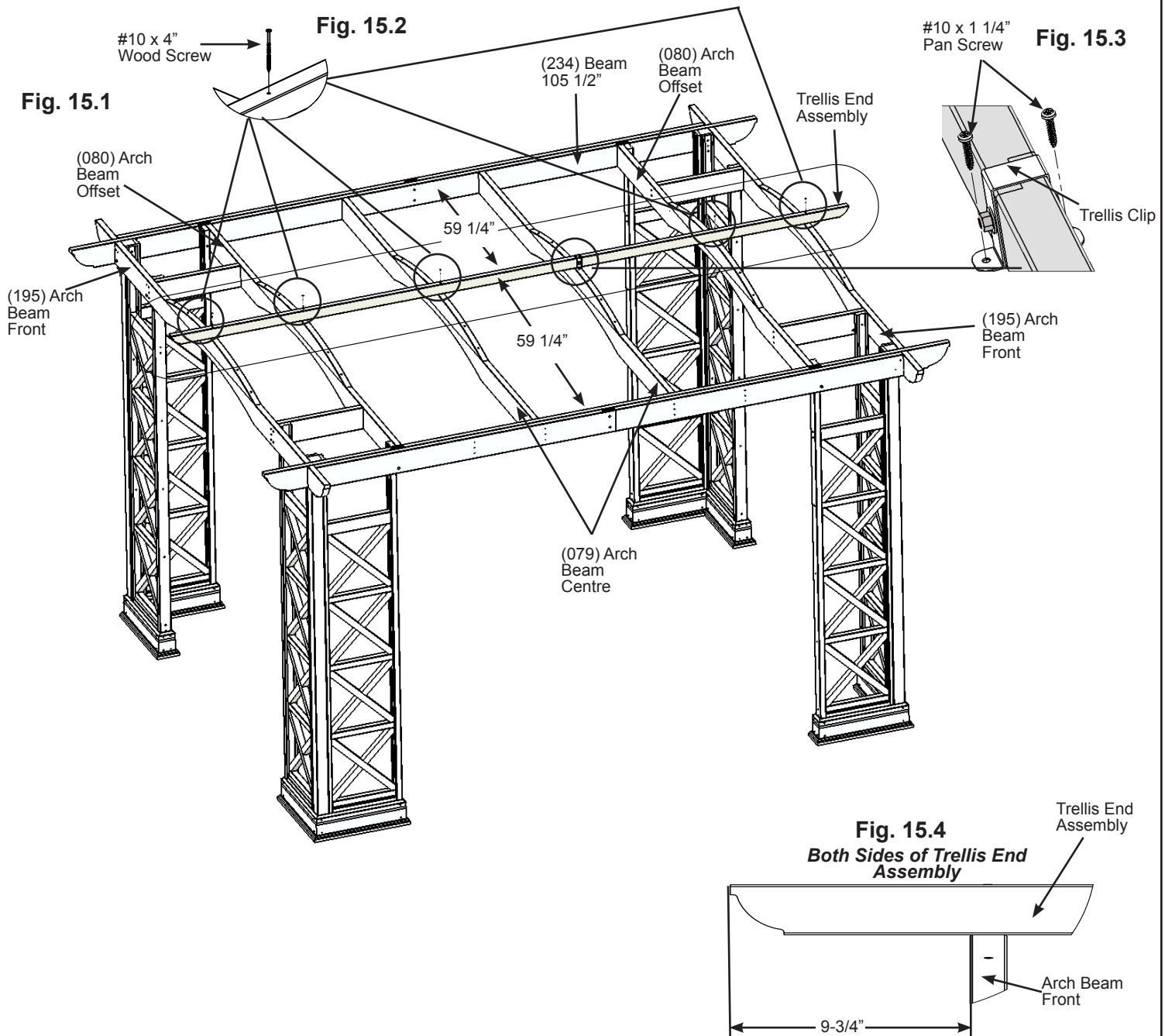

Hardware
 5 x #10 x 4" Wood Screw
 2 x #10 x 1-1/4" Pan Screw

Step 15: Attach Trellis End Assemblies Part 2

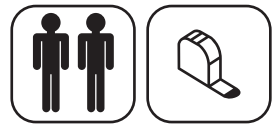

D: Starting at the centre Trellis End Assembly and working outwards attach four Trellis End Assemblies on either side alternating each Trellis End Assembly so the Trellis Clip is on opposing sides to the assemblies next to it. (fig. 15.5)

Note: The distance between assemblies should be 12" (fig. 15.6)

Note: Refer to previous page, fig 15.2 and 15.3 for attaching trellis clip.

Fig. 15.5

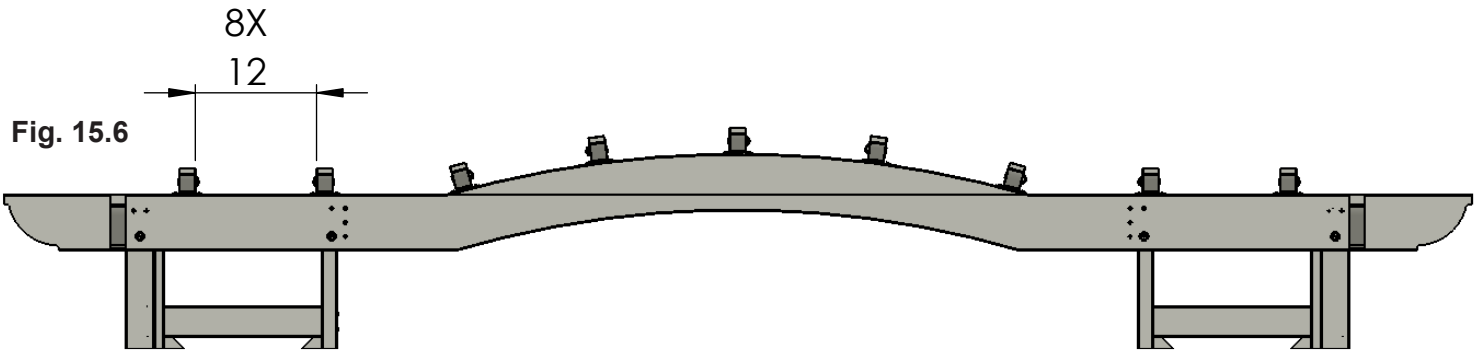
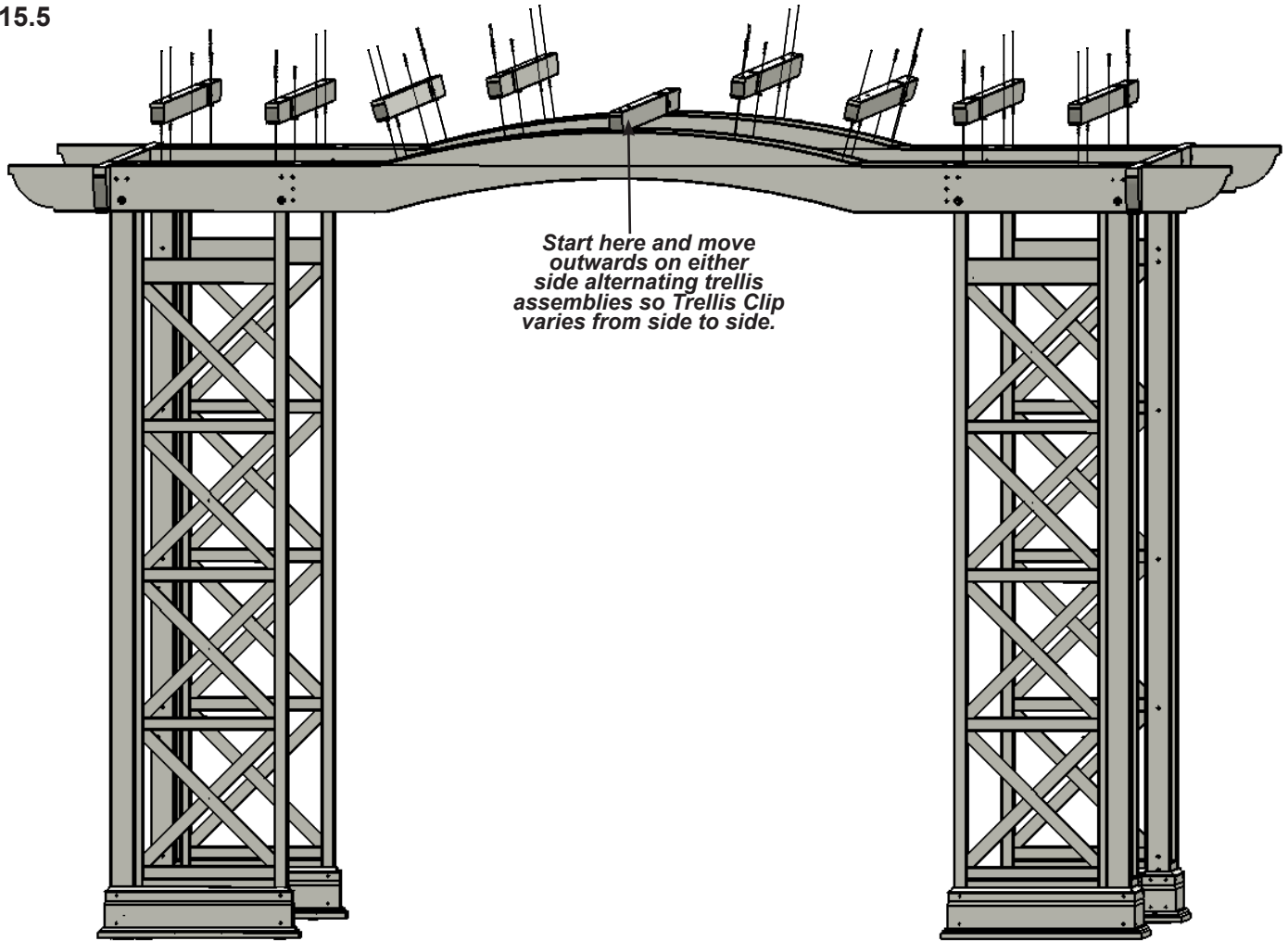

Fig. 15.6

Hardware

40 x #10 x 4" Wood Screw

16 x #10 x 1-1/4" Pan Screw

Step 16: Attach Left and Right Arch Gussets Part 1

Note: The bevelled ends on each Arch Gusset should always face away from the wood it is attaching to.

A: At two corners of the assembly attach one (194) Arch Gusset Left to the (241) Engineered Panel Post Long with one #8 x 3" Wood Screws and flush to the inside, bottom edge of the (079) Arch Beam Front with two #8 x 2-1/2" Wood Screws as shown in fig. 16.1 and 16.2. These should be opposing corners. Attach a (193) Arch Gusset Right on the other two corners.

B: Repeat for opposite side.

Fig. 16.1

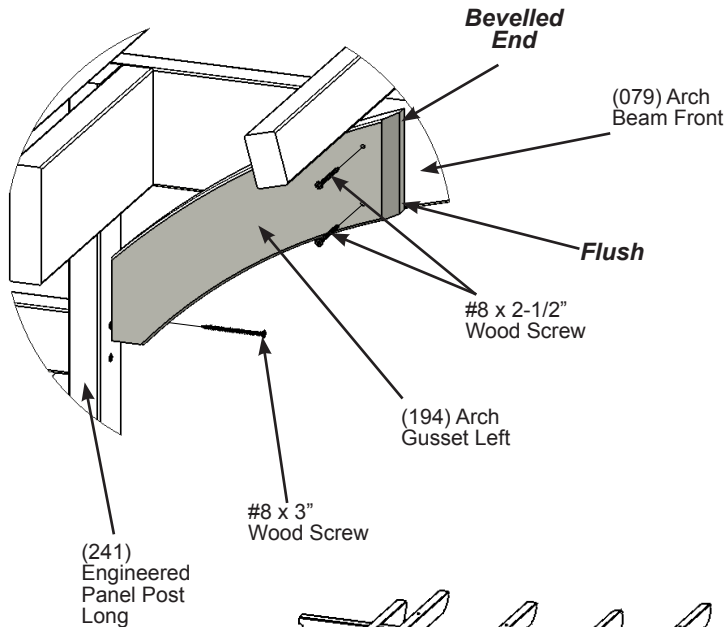
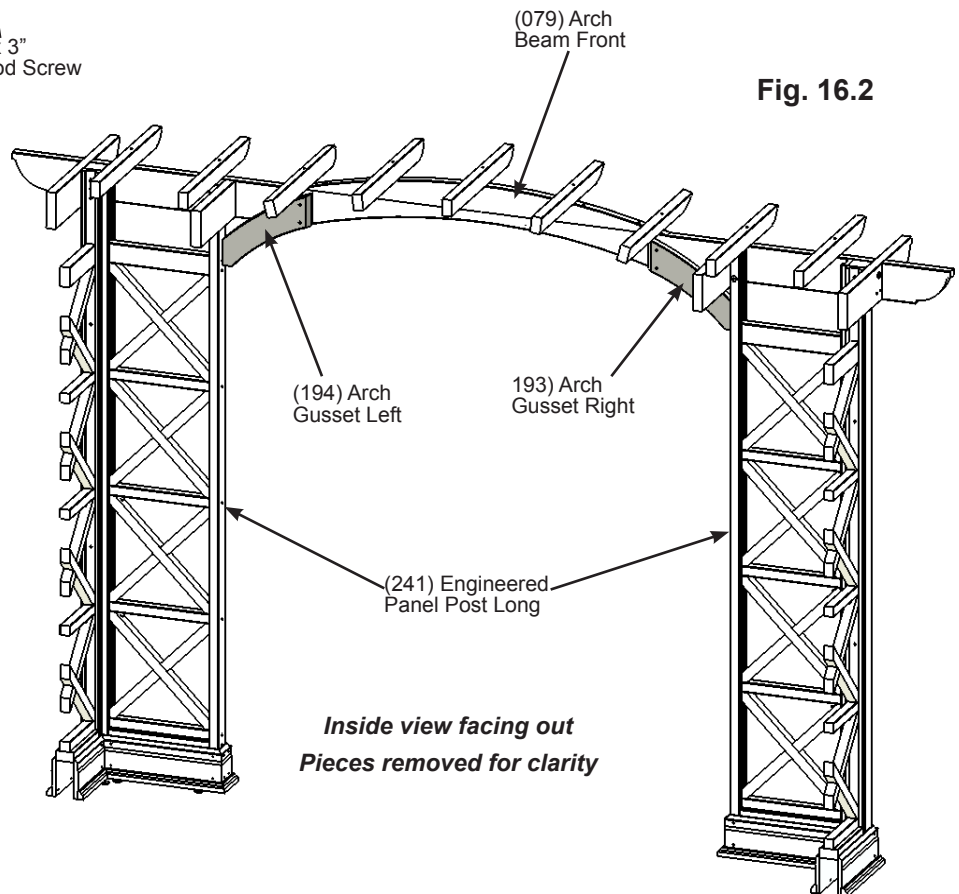

Fig. 16.2



Wood Parts

- 2 x (193) Arch Gusset Right 36 x 127 x 453.2 mm
- 2 x (194) Arch Gusset Left 36 x 127 x 453.2 mm

Hardware

- 8 x #8 x 2-1/2" Wood Screw
- 4 x #8 x 3" Wood Screw

Step 16: Attach Left and Right Arch Gussets Part 2

Note: The bevelled ends on each Arch Gusset should always face away from the wood it is attaching to.

C: Attach one (237) Arch Gusset Right Long or one (236) Arch Gusset Left Long to the remaining (241) Engineered Panel Post Longs using two #8 x 3" Wood Screws and to the (234) Beam 105 1/2" with three #8 x 2-1/2" Wood Screws as shown in fig. 16.3 and 16.4. Each corner of the assembly should have one (237) Arch Gusset Right Long and one (236) Arch Gusset Left Long.

Fig. 16.3

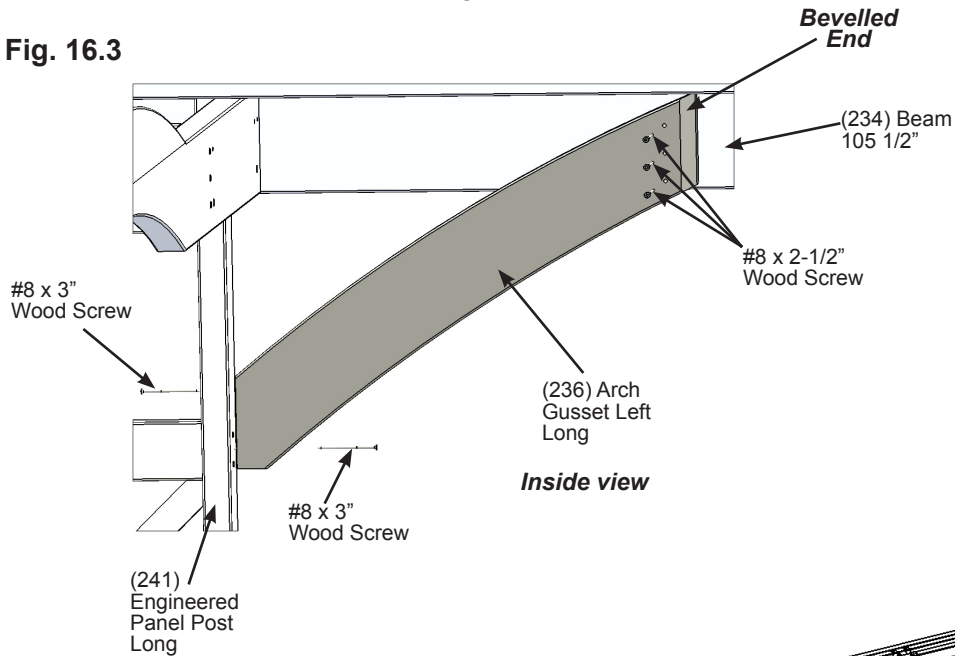
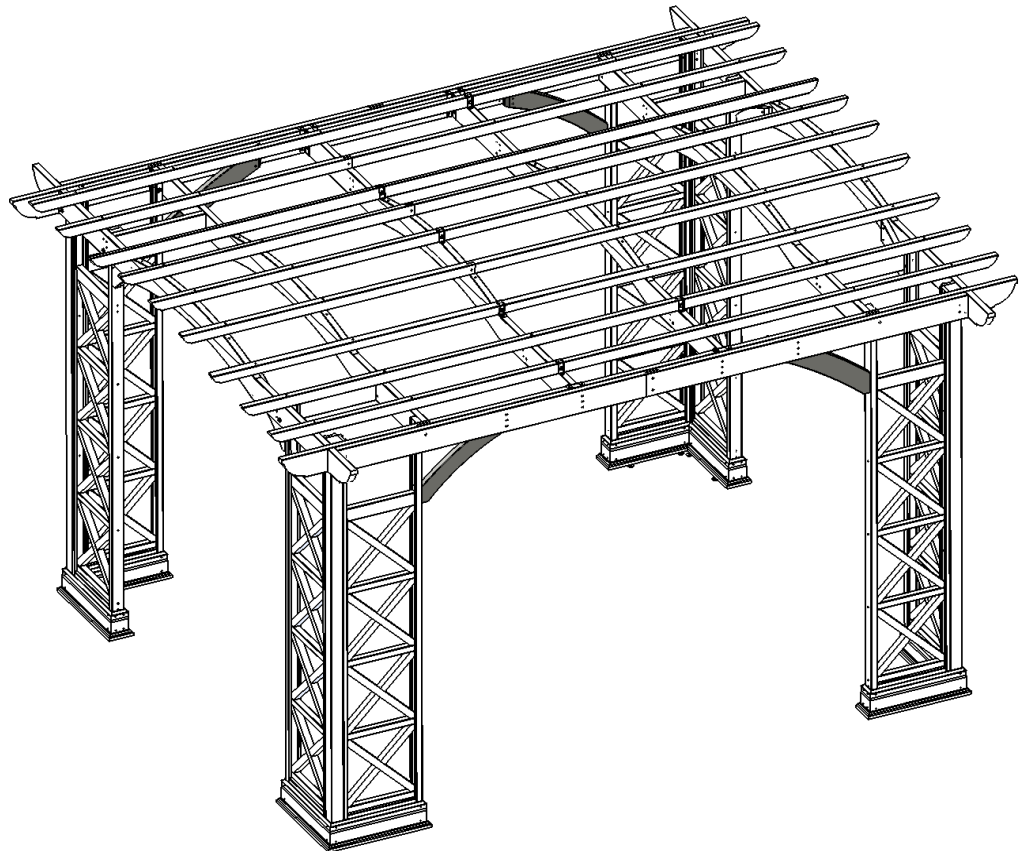

Fig. 16.4



Wood Parts

2 x (237) Arch Gusset Right Long 36 x 139.7 x 762 mm
2 x (194) Arch Gusset Left 36 x 139.7 x 762 mm

Hardware

12 x #8 x 2-1/2" Wood Screw
8 x #8 x 3" Wood Screw

